

Испытательная система для беспроводной связи TS8991

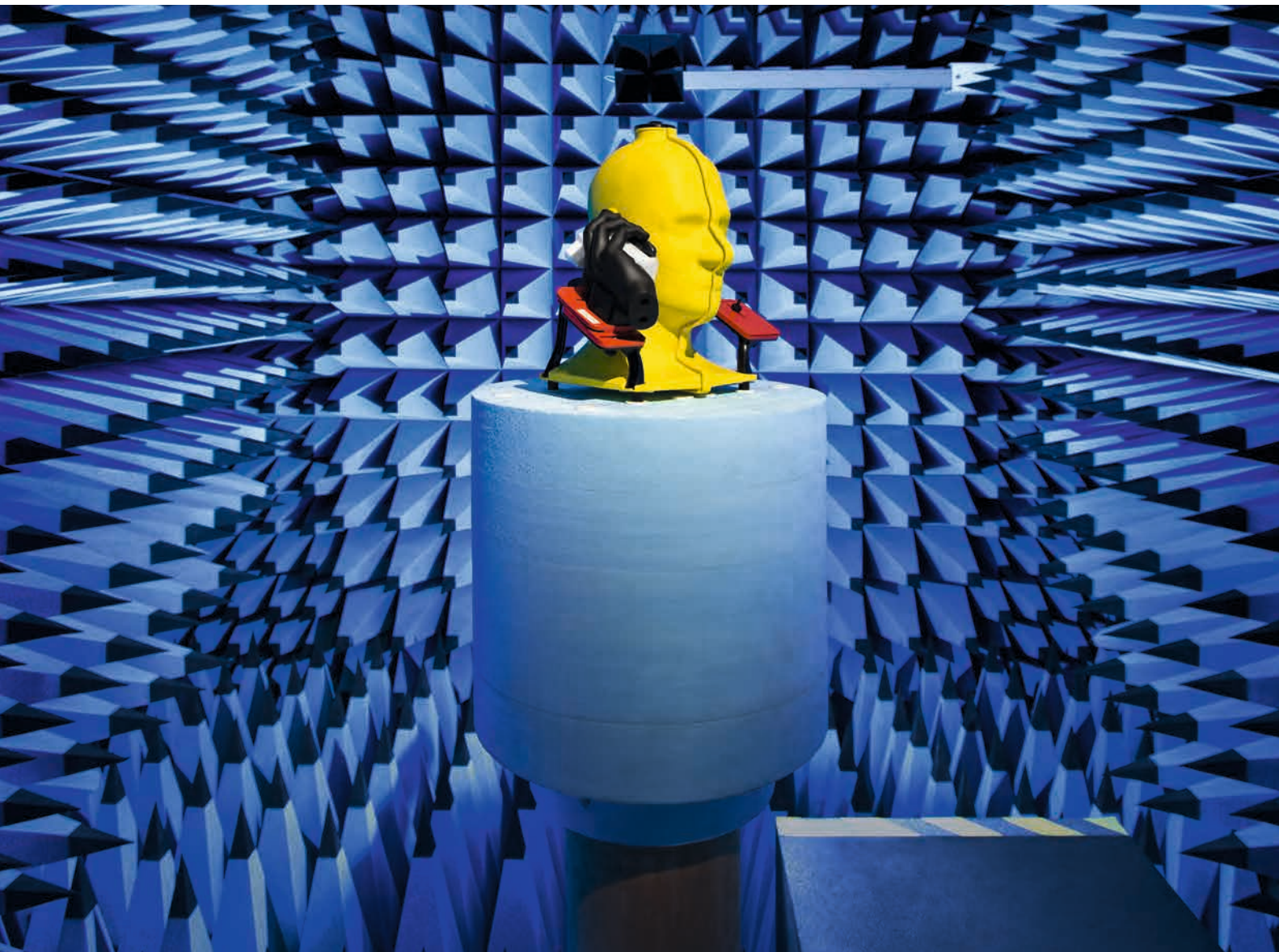

Архангельск (8182)63-90-72
Астана (7172)727-132
Астрахань (8512)99-46-04
Барнаул (3852)73-04-60
Белгород (4722)40-23-64
Брянск (4832)59-03-52
Владивосток (423)249-28-31
Волгоград (844)278-03-48
Вологда (8172)26-41-59
Воронеж (473)204-51-73
Екатеринбург (343)384-55-89
Иваново (4932)77-34-06

Ижевск (3412)26-03-58
Иркутск (395)279-98-46
Казань (843)206-01-48
Калининград (4012)72-03-81
Калуга (4842)92-23-67
Кемерово (3842)65-04-62
Киров (8332)68-02-04
Краснодар (861)203-40-90
Красноярск (391)204-63-61
Курск (4712)77-13-04
Липецк (4742)52-20-81

Магнитогорск (3519)55-03-13
Москва (495)268-04-70
Мурманск (8152)59-64-93
Набережные Челны (8552)20-53-41
Нижний Новгород (831)429-08-12
Новокузнецк (3843)20-46-81
Новосибирск (383)227-86-73
Омск (3812)21-46-40
Орел (4862)44-53-42
Оренбург (3532)37-68-04
Пенза (8412)22-31-16

Пермь (342)205-81-47
Ростов-на-Дону (863)308-18-15
Рязань (4912)46-61-64
Самара (846)206-03-16
Санкт-Петербург (812)309-46-40
Саратов (845)249-38-78
Севастополь (8692)22-31-93
Симферополь (3652)67-13-56
Смоленск (4812)29-41-54
Сочи (862)225-72-31
Ставрополь (8652)20-65-13

Сургут (3462)77-98-35
Тверь (4822)63-31-35
Томск (3822)98-41-53
Тула (4872)74-02-29
Тюмень (3452)66-21-18
Ульяновск (8422)24-23-59
Уфа (347)229-48-12
Хабаровск (4212)92-98-04
Челябинск (351)202-03-61
Череповец (8202)49-02-64
Ярославль (4852)69-52-93

Киргизия (996)312-96-26-47

Россия (495)268-04-70

Казахстан (772)734-952-31

<https://rohdeschwarz.nt-rt.ru> || rwz@nt-rt.ru

R&S®TS8991 OTA Performance Test System At a glance

The R&S®TS8991 OTA performance test system performs OTA measurements for all important wireless and mobile standards.

R&S®TS8991 test chamber and system rack (courtesy of 7Layers).



Wireless enabled devices have to pass a variety of industry and regulatory certifications before they can be sold. These certifications include regulatory/compliance testing such as EMC, conformance testing such as protocol, RF, RRM or LBS, as well as performance testing such as over-the-air (OTA). Generally, conformance testing is performed at the conducted port(s) of the device under test (DUT) and is based on pass/fail tests. While the original equipment manufacturers (OEMs) can skip conformance testing by integrating precertified modules in their devices, the radiated device certification tests have to be performed for every wireless-enabled device.

provides system solutions for the majority of wireless-enabled device certification tests.

An OTA performance test system is used to analyze and optimize the radiated device performance and to validate conformance with industry, network operator and internal company requirements. Specifically, the antenna patterns as well as the transmitter and receiver chain wireless system performance such as TRP and TIS/TRS, respectively, are verified with an OTA system. These measurements follow test plans and detailed test and setup procedures published by industry organizations such as CTIA and 3GPP.

The R&S®TS8991 OTA performance test system is a full turnkey solution that includes an anechoic chamber, positioning equipment, test instruments and automated measurement software. is the only system integrator that can provide a turnkey solution consisting of system software and test equipment using in-house designed and sourced components.

The featured R&S®CMW500 communication tester supports all relevant mobile and wireless standards in one instrument. Technology upgrades to the system require only minimal software and hardware upgrades and can be performed very easily and cost effectively.

Key facts

- Compliant with CTIA, joint CTIA&Wi-Fi Alliance® and 3GPP test plans
- Modular system design for customer-specific configuration
- Single vendor solution
- Flexible and upgradeable system concept
- Turnkey solutions ranging from entry-level R&D to large form factor solutions
- Cellular (2G, 3G, LTE, LTE carrier aggregation) and non-cellular (A-GNSS, WLAN, Bluetooth®) OTA testing capabilities

R&S®TS8991 OTA Performance Test System Benefits and key features

Common OTA measurements

- ▮ Total radiated power (TRP)
- ▮ Total isotropic sensitivity (TIS, per CTIA) and total radiated sensitivity (TRS, per 3GPP)
- ▮ Radiated sensitivity on intermediate channels (RSIC)
- ▮ Coexistence measurements
- ▮ Passive antenna measurements/efficiency
- ▮ Signaling vs. non-signaling measurements
- ▮ List of typical OTA measurements

▷ [page 4](#)

R&S®TS8991 equipment rack

- ▮ Flexible and scalable
- ▮ Large number of supported OTA measurement technologies
- ▮ User-specific configurations

▷ [page 6](#)

Entry-level OTA setup with the R&S®DST200 RF diagnostic chamber

- ▮ Compact test solution
- ▮ Fully automated OTA measurements with 3D positioners
- ▮ Multiple feedthrough panels – functional test interfaces

▷ [page 8](#)

Wireless performance test chamber (WPTC)

- ▮ Anechoic chamber: Albatross Projects Group
- ▮ Positioning system: maturo
- ▮ User-specific solution: add-ons

▷ [page 10](#)

Turnkey and custom WPTC systems

- ▮ For all needs
- ▮ Many different sizes: from XS to XL
- ▮ Optional features for further adjustments

▷ [page 12](#)

R&S®AMS32 OTA performance measurement software

- ▮ Automated measurements
- ▮ Ready-to-use test templates
- ▮ Unique viewer and test sequencer
- ▮ Simple extension: EMC measurements
- ▮ Result documentation made easy: straightforward result display
- ▮ Near-field far-field (NF-FF) transformation
- ▮ Modular technology options
- ▮ Optimized test times

▷ [page 14](#)

Cellular OTA testing

- ▮ TRP measurements with simultaneous EIRP measurements
- ▮ TRP measurements using two antenna arms
- ▮ TIS measurements
- ▮ CA measurements

▷ [page 16](#)

Non-cellular OTA testing

- ▮ Assisted global navigation satellite system (A-GNSS) testing
- ▮ WLAN testing
- ▮ Bluetooth® testing

▷ [page 18](#)



The R&S®CMW500 wideband radio communication tester supports all relevant mobile and wireless standards in one instrument.

Common OTA measurements

The R&S®TS8991 OTA performance test system not only performs OTA measurements according to industry (CTIA and 3GPP) specifications, it also allows customizations with improved test speeds for R&D purposes. The most comprehensive OTA test plan is the CTIA “Test Plan for Wireless Device Over-the-Air Performance”, which specifies the measurement method for radiated RF power and receiver performance of wireless enabled devices. Key OTA measurements are summarized briefly below.

Total radiated power (TRP)

The TRP is a figure of merit for the transmitter performance of the DUT. The radiation pattern is generally measured every 15° in both azimuth and elevation using a dual-linear polarized test antenna to capture two principal polarizations, theta and phi, either simultaneously or sequentially. At each position and for each polarization, the equivalent isotropic radiated power (EIRP) is measured and the TRP corresponds to a spatial average of EIRP values taken uniformly around the DUT. The difference between the TRP and the conducted TX power, i.e. the power delivered to the antenna, is an approximation of the antenna efficiency.

Alternatively, a spiral scan approach can be used to perform TRP measurements significantly faster with no loss in accuracy. This methodology utilizes the simultaneous measurement of EIRPs in both principal polarizations and the continuous rotation of azimuth and elevation positioners. The test points thus traverse a spiral path around the DUT.

Total isotropic sensitivity (TIS, per CTIA) and total radiated sensitivity (TRS, per 3GPP)

TIS/TRS is a figure of merit for the receiver performance of the DUT and utilizes error rate measurements such as bit error rate (BER), block error rate (BLER), packet error rate (PER), etc. The radiation pattern is generally measured every 30° in both azimuth and elevation. At each position and for each polarization, the effective isotropic sensitivity (EIS) is determined, i.e. the downlink power level at which the DUT reports a target error rate. TIS/TRS corresponds to a spatial average of EIS values taken uniformly around the DUT. The difference between the conducted sensitivity and TIS/TRS is an approximation of the antenna efficiency assuming that self-interference (desense), i.e. the degradation of the sensitivity due to noise sources, is negligible.

Alternatively, the receive signal strength (RSS) based approach can be used to perform TIS measurements for technologies that support reporting of RSS, e.g. GSM, WCDMA, LTE, etc. This methodology starts with the collection of RSS values that the DUT reports at a fixed downlink power level. This RSS pattern is sampled uniformly around the DUT similarly to the classical measurement approach described above. At the peak of this pattern, a linearization is performed that relates RSS to downlink power levels. In the last step, the EIS is measured at the peak of the pattern. The RSS pattern, the linearization and the EIS at the peak of the pattern are then used to calculate the remaining EIS values and subsequently TIS/TRS.

Classical TRP test approach

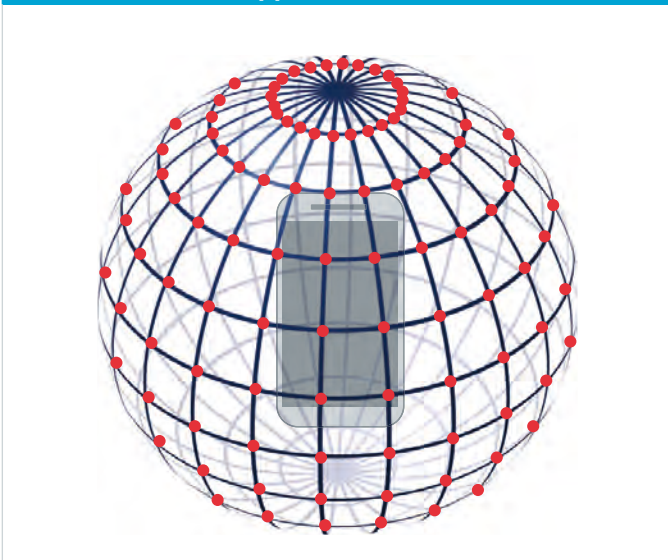

Spiral-scan TRP test approach

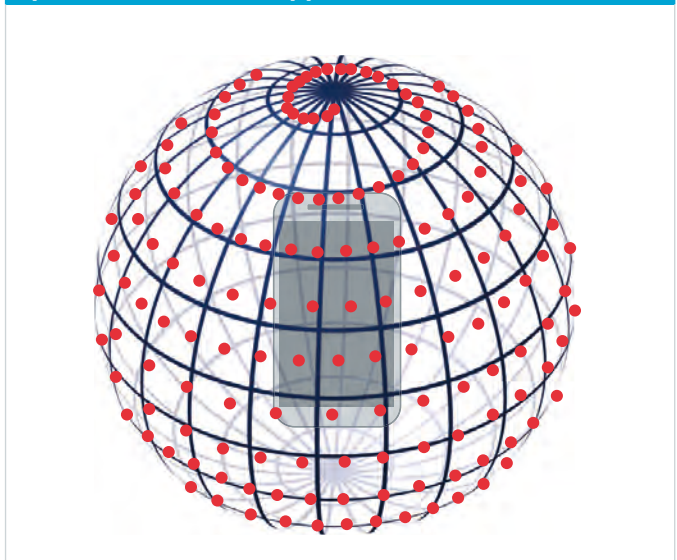

Radiated sensitivity on intermediate channels (RSIC)

Typically, only three channels per band are evaluated for TIS/TRS, which could leave a large amount of channels untested within a given band. RSIC tests provide a quick assessment of the presence of desense within the band of interest using error rate measurements at the peak positions of the TIS pattern and at fixed downlink power levels. The level of the measured error rates quickly determines whether the receiver is desensitized by internal noise sources on a given channel.

Coexistence measurements

Coexistence measurements assess the interference of one technology/protocol on another. Typically, error rate measurements at a fixed position are performed on the receiver of interest with and without the other technology/protocol active. The difference in error rate is a measure of the interference and whether two technologies can coexist in simultaneous operation.

Passive antenna measurements/efficiency

Passive antenna measurements solely focus on the antenna transmit/receive performance by quantifying the relative field strength transmitted/received by the antenna. Passive testing is usually performed to optimize the antenna gain, efficiency and patterns. Traditionally, a vector network analyzer (VNA) is used for this measurement, which allows measurement of the magnitude and phase patterns.

The efficiency of the antenna is the ratio of the power radiated by the antenna to the power accepted by the antenna.

The phase of the antenna patterns can be used to determine other important antenna parameters such as circular

polarization and antenna correlation coefficients, and for near-field to far-field transformations.

Signaling vs. non-signaling measurements

Signaling measurements utilize a communication tester to emulate a “real-life” connection, including the physical layer. Most industry test cases are based on signaling measurements.

Non-signaling measurements, supported by test modes, primarily use signal generators and signal analyzers because the DUT is operated without any signaling stack.

The R&S®TS8991 system is capable of performing signaling and non-signaling measurements.

List of typical OTA measurements

- TRP/EIRP, TIS/TRS/EIS
- RSIC for cellular technologies/desense
- Intermediate channel desense (ICD) for A-GNSS
- Coexistence
- Single-point offset measurement (SPOM)
- Gain, directivity, efficiency, beam width, front-to-back ratio (FTBR)
- 2D and 3D radiation patterns
- Envelope correlation coefficient (ECC) between two antennas
- Circular polarization (LHCP, RHCP and axial ratio)

Classical TIS test approach

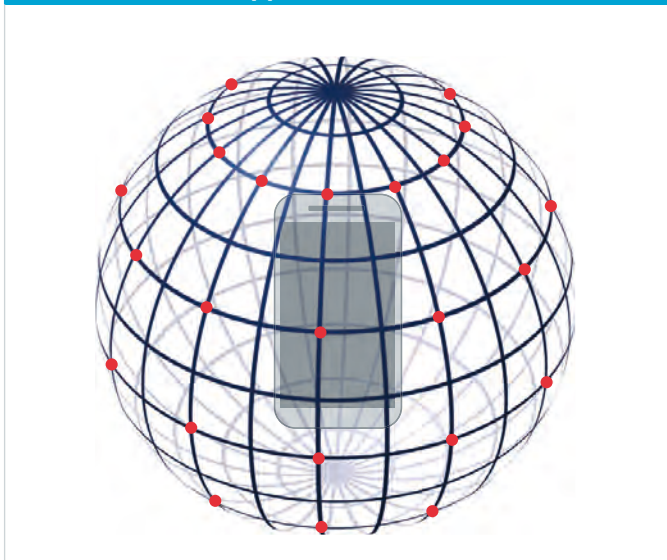

Desense test approach using RSIC

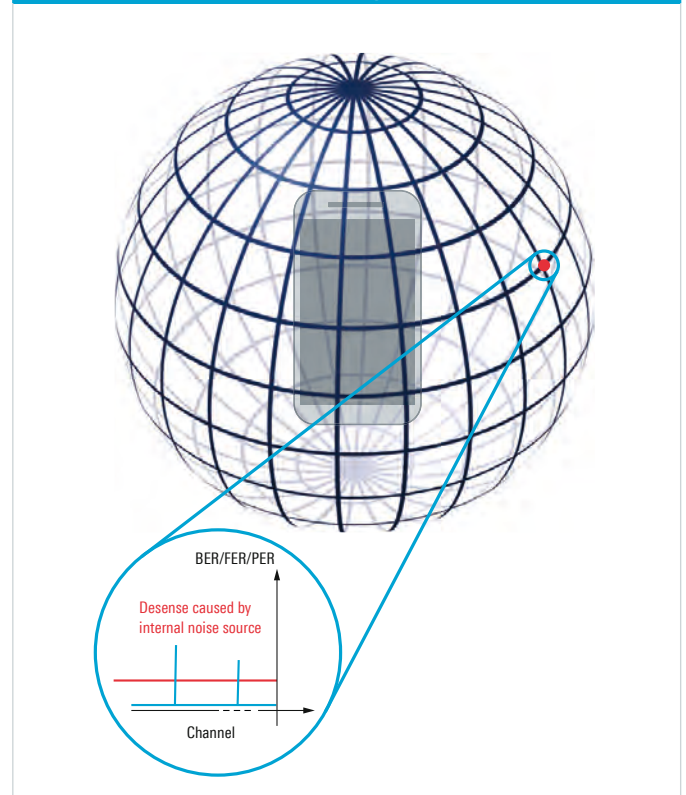

R&S®TS8991 equipment rack

Flexible and scalable

The R&S®TS8991 OTA performance test system can be flexibly configured to meet user-specific requirements. The flexible equipment hardware and software allows simple upgrading and offers scalable features, which helps reduce system downtime, complexity and cost.

Large number of supported OTA measurement technologies

The R&S®TS8991 system supports the following technologies:

- ▮ LTE-FDD, TD-LTE
- ▮ LTE-U
- ▮ LTE carrier aggregation 2/3/4 DL CA with single UL
- ▮ WCDMA/HSPA/HSPA+
- ▮ TD-SCDMA
- ▮ GSM/GPRS/EDGE
- ▮ CDMA2000® 1xRTT, CDMA2000® 1xEV-DO
- ▮ A-GNSS (A-GPS, A-Glonass)
- ▮ WLAN (IEEE 802.11 a/b/g/n)
- ▮ Bluetooth®

Use of the R&S®CMW500 for all technologies

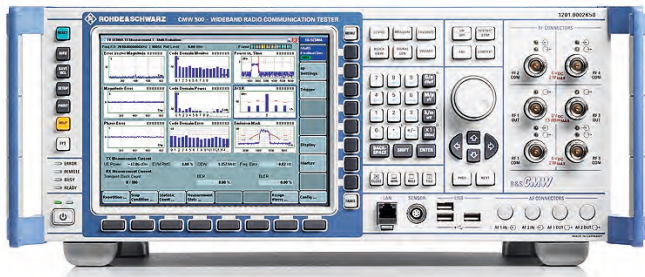
WCDMA	HSPA	HSPA+	DC-HSPA	CDMA2000® 1xRTT	CDMA2000® 1xEV-DO	LTE-FDD					
EDGE evolution, VAMOS						TD-LTE					
GSM, (E)GPRS						TD-SCDMA					
FM Stereo™						WLAN IEEE 802.11a/b/g/n					
DVB-T						CMMB	T-DMB	GPS	Glonass	Galileo	Bluetooth® BR, EDR, LE
Cellular						Non-cellular					

User-specific configurations

The technologies offered by the R&S®TS8991 system are all supported by the unique, all-in-one test platform for wireless communications: the R&S®CMW500 wideband radio communication tester. The cellular and non-cellular technologies supported by the R&S®CMW500 are illustrated in the figure on the left.

A-GNSS, e.g. A-GPS and A-Glonass, testing requires an additional R&S®SMBV100A vector signal generator/GNSS satellite system simulator to create the GNSS signals.

LTE MIMO testing requires an additional R&S®SMW200A vector signal generator that serves as a baseband fading emulator for 2x2 MIMO using spatial channel model extended (SCME) channel models.

TRP measurements can be performed with the R&S®CMW500; a spectrum analyzer is recommended to achieve a larger dynamic range and faster test times. The most cost-effective and generally fastest TRP solution utilizes power sensors since EIRPs from both principal polarizations can be captured simultaneously.

A vector network analyzer is used for ripple testing to characterize the reflections within the chamber, for path loss/chamber calibrations and for passive testing of antennas.

The R&S®OSP open switch platform is used for RF switching of equipment ports to the respective antenna ports inside the anechoic chamber. For optional WLAN/Bluetooth® support, the R&S®OSP can be upgraded to include amplification of WLAN/Bluetooth® uplink and downlink paths.

The maturo NCD is the multi-device positioning controller interfacing with the positioners inside the anechoic chamber.

R&S®TS8991 equipment rack



R&S®SMW200A: LTE MIMO

R&S®SMBV100A: A-GPS, A-Glonass

R&S®CMW500: 2G/3G/LTE (SISO and MIMO), TD-SCDMA, WLAN, Bluetooth®, A-GNSS, carrier aggregation

maturo NCD controller: manual positioner control, laser alignment system control

R&S®OSP130: RF switching, amplification

R&S®FSV/R&S®FSW: TRP, RSE

R&S®ZNBx, R&S®ZND: ripple test, calibration, antenna efficiency

R&S®NRP2 + 2 × or 4 × R&S®NRP8S: TRP

Entry-level OTA setup with the R&S®DST200 RF diagnostic chamber

Compact test solution

The bench-top R&S®DST200 RF diagnostic chamber provides a compact OTA test solution for diagnostic OTA measurements. Due to its small size and low cost, it is ideal for customers with limited lab space or budget. It is well suited for customers who need an entry-level diagnostic system for fast and reliable estimation of the OTA performance of wireless enabled devices. Radiated testing during R&D phases ensures faster time to market and reduces costs and engineering resources. The individual path loss calibration delivers an excellent correlation to larger OTA test chambers.

With a frequency range from 400 MHz to 18 GHz, the R&S®DST200 can be used to test all common wireless standards. Its modular design with accessible top and bottom compartments provides flexibility for installing additional hardware and interfaces to accommodate specific test requirements.

R&S®DST200 RF diagnostic chamber.



Fully automated OTA measurements with 3D positioners

The most basic R&S®DST200 configuration includes a flat table for desense and conducted measurements. When the R&S®DST200 is used for OTA measurements, two different automated 3D positioners are offered: a phone positioner and a tablet positioner. Both positioners are controlled by the R&S®AMS32 test and measurement software, allowing fully automated 3D OTA measurements for some of the most common devices.

Multiple feedthrough panels – functional test interfaces

Many tests require access to the DUT's external interfaces. Typical tests cover charger functionality, operation of the test mode interface, data throughput and turning on or off components such as the display or camera. The bottom compartment provides three locations for installing various RF feedthroughs and filtered lines:

- 9-pin D-Sub lowpass filter and two fiber-optic feedthrough connectors
- Two N-type feedthrough connectors
- USB 2.0 lowpass filter
- 100 V to 240 V AC feedthrough filter

Key facts for the R&S®DST200 RF diagnostic chamber

- Anechoic RF chamber with shielding effectiveness > 110 dB for interference-free testing in unshielded environments
- Wide frequency range from 400 MHz to 18 GHz covering all important wireless standards
- Compact dimensions suitable for any lab environment
- Unique mechanical design provides long-term stability and maintains high shielding effectiveness
- Simple and effective front door locking mechanism without pneumatic components
- Automated 3D positioner for OTA and RSE pre-compliance measurements

Automated 3D phone positioner (R&S®DST-B160).

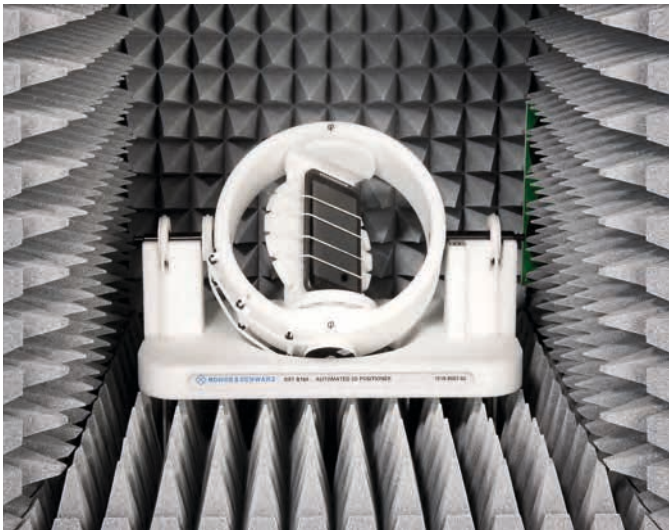

Automated 3D tablet positioner (R&S®DST-B165).



Wireless performance test chamber (WPTC)

One key component of the R&S®TS8991 OTA test system is the anechoic chamber. The aim of such a test site is to create an environment that yields not only accurate, but repeatable and reproducible measurements. In close cooperation with our partners, a total of five standardized wireless performance test chambers were designed.

Anechoic chamber: Albatross Projects Group has a reliable long-term partnership with Albatross Projects in the area of EMC and OTA turnkey solutions. Some of the main differentiators of the offered an-echoic chambers are the pan-type shielding approach, the doors and the absorbers.

Pan-type shielding is used for WPTCs where stainless steel shielding panels are cut, bent and punched to standardized dimensions. Panels are bolted and all connections use high-performance RF wire mesh or gasket material.

This approach offers superior shielding effectiveness with typical results of 100 dB and better. This performance is sustained over the long term since the shielding performance is not impacted by changes in seasons, temperatures or humidity.

The shielded doors are built into side panels using the pan-type shielding approach and offer superior performance as well as easy maintenance. The doors consist of a metal frame, contact springs and metal door leaf, which has the advantage that opening and closing the door has a self-cleaning effect on the contact surfaces.

The doors utilize either pneumatic or electric actuation for comfortable handling at the push of a button.

The absorbers for the wireless performance test chambers are developed and manufactured by Albatross Project's subsidiary Emerson&Cuming Anechoic Chambers NV. For the OTA chambers, the WAVASORB VHP absorbers are used. This solid, pyramidal shaped, carbon-loaded, urethane foam absorber provides the highest broadband performance of all known absorber types at both normal incidence angles and at wide incidence angles.

All WPTCs come equipped with honeycomb inserts, interior lighting, RF and fiber-optic feedthroughs as well as power line filters.

AlbatrossProjects

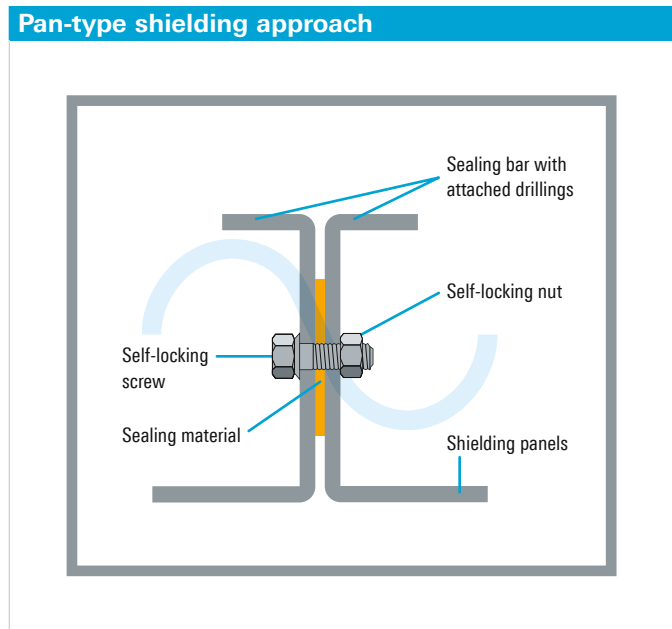

Pneumatic door.

Positioning system: maturo

A fast, accurate and reliable positioning system ensures short measurement cycles and high repeatability and reproducibility of test results. The maturo positioners ensure highly accurate azimuth and elevation positioning systems. The precision drives include integrated absolute positioning sensors. Multiple cross-hair laser beams enable accurate centering of the DUT placed on the azimuth positioner.

A second elevation positioner can be added for MIMO OTA measurements, but it could also be used for faster TRP measurements.

The conical-cut systems, achieved with the maturo positioners, allow much more straightforward and faster device setup as well as heavier DUTs when compared with some traditional great circle cut systems. The WPTC conical cut positioner systems have one high-performance antenna moving mechanically around the DUT. Multiprobe systems, on the other hand, utilize multiple probes distributed around the DUT that are electronically switched in and out with the following disadvantages:

- ▮ Probes have worse antenna performance than the dual-linear polarized high-performance antenna

- ▮ Neighboring probes exhibit coupling effects
- ▮ Calibration of probes requires a complex and costly calibration procedure that leads to lengthy system downtime; conical cut positioner systems, on the other hand, just require a simple and quick path loss calibration

User-specific solution: add-ons

provides turnkey solutions for OTA measurements. A wide range of accessories is available for the anechoic chamber and positioner:

- ▮ Phantom head and hands
- ▮ Dipole and loop antennas
- ▮ Slip ring (Ethernet, RS-232, AC power) integrated into the turntable
- ▮ Chair for azimuth positioner
- ▮ Heavy-duty turntable
- ▮ Ripple test kit
- ▮ Audio/video monitoring system
- ▮ Earthquake protection kit
- ▮ Sprinkler system
- ▮ Smoke detection system

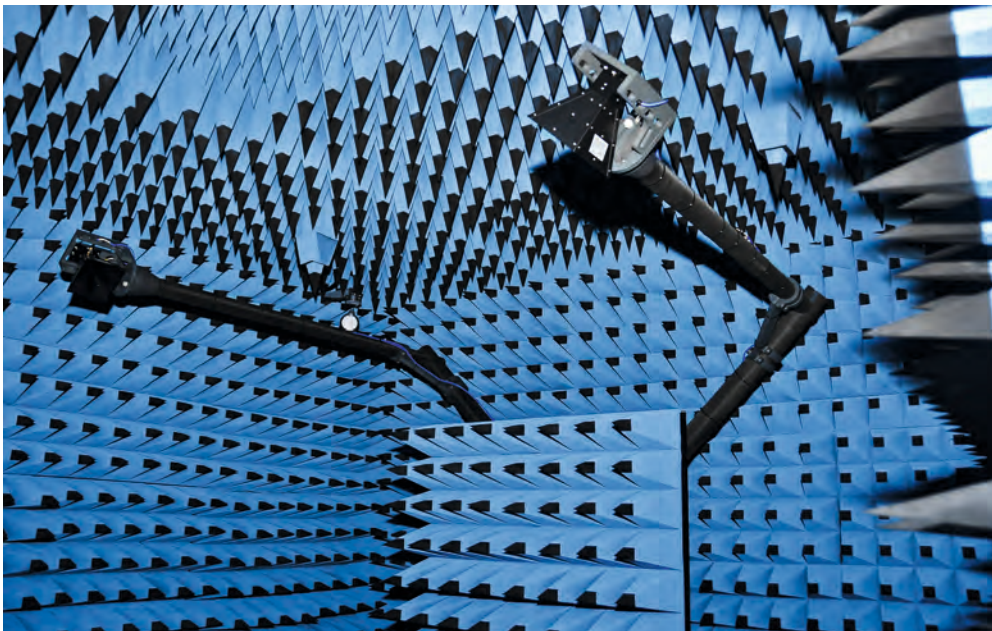

Dual-arm maturo positioner system for MIMO OTA and faster TRP measurements.

Turnkey and custom WPTC systems

For all needs

A variety of turnkey WPTC systems have been designed to meet the needs of most customers and applications. The smaller systems are highly suitable for customers with smaller budgets, little lab space or mostly small UE sizes. The larger systems are primarily suitable for customers that need to be CTIA-compliant, e.g. third-party labs, and therefore need to meet a minimum range length between the measurement antenna and the center of the quiet zone. However, WPTC systems can also be custom designed to meet customer requirements in terms of size, functionality, frequency range and applications.

Many different sizes: from XS to XL

The turnkey WPTC models, ranging from XS to XL, have been designed for the majority of wireless communications applications. The anechoic chamber for models XS to M have absorber linings to cover frequencies down to approx. 600 MHz while the larger L and XL models have larger absorbers that cover frequencies down to approx. 400 MHz. By default, the upper frequency of the systems is approx. 18 GHz, but could be increased if needed. The range lengths for the smaller two systems, XS and S, are too small to be CTIA-compliant (1.2 m). The systems M through XL are large enough to be CTIA-compliant. Systems XS and S include 90 cm wide doors with electrical actuation. The larger systems include 120 cm wide doors with pneumatic actuation.

WPTC model overview					
Model	WPTC-XS	WPTC-S	WPTC-M	WPTC-L	WPTC-XL
Outer dimensions of shielding panels, W x H x D	2.43 m x 2.40 m x 2.43 m (7.97 ft x 7.87 ft x 7.97 ft)	3.70 m x 3.00 m x 3.10 m (12.14 ft x 9.84 ft x 10.17 ft)	4.60 m x 3.45 m x 3.70 m (15.09 ft x 11.32 ft x 12.12 ft)	5.20 m x 4.05 m x 4.30 m (17.06 ft x 13.29 ft x 14.12 ft)	5.80 m x 5.10 m x 5.20 m (9.03 ft x 16.73 ft x 17.06 ft)
Frequency range of test chamber	0.6 GHz to 18 GHz	0.6 GHz to 18 GHz	0.6 GHz to 18 GHz	0.4 GHz to 18 GHz	0.4 GHz to 18 GHz
Typical range length	> 0.65 m (2.2 ft)	> 1.02 m (3.3 ft)	> 1.30 m (4.3 ft)	> 1.38 m (4.5 ft)	> 1.83 m (6.0 ft)
CTIA-compliant	no (R&D)	no (R&D)	yes	yes	yes

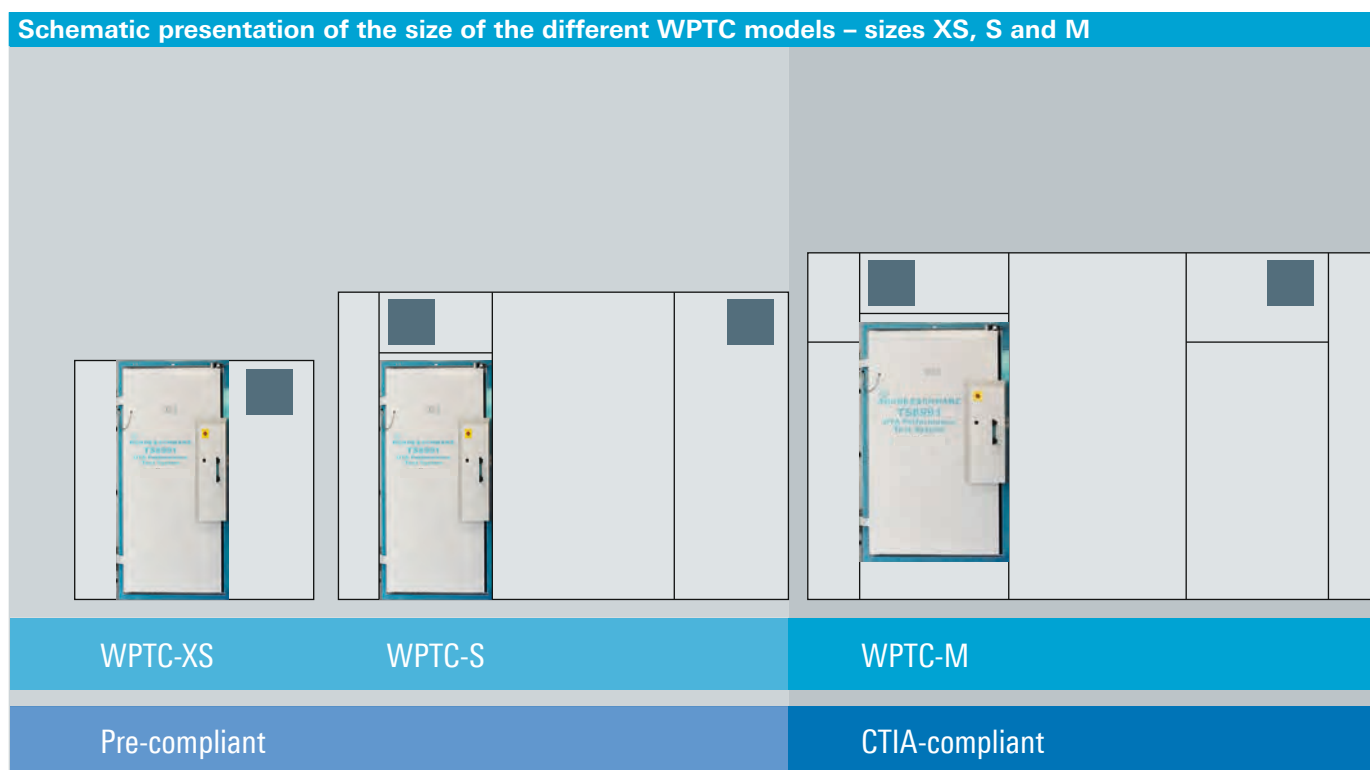

All systems include high-performance, dual-linear polarized measurement antennas covering a frequency range from 600 MHz to 18 GHz. Lower frequency antennas that reduce the range length slightly are available for the L and XL systems.

Every system includes one antenna arm for typical SISO antenna measurements. A second antenna arm including a second antenna can be added for LTE MIMO measurements, but this additional arm/antenna could also be used for faster TRP measurements.

Example model: XS

The XS model is the most compact system that is highly suitable for R&D applications and integration into office and smaller lab environments. Optionally, the system can be placed on casters to move it between different locations if needed. The full-sized door enables easy access to the turntable and installation/removal of the UE.

Example model: XL

The XL model is the largest turnkey system and allows very large devices to be tested. The large door with pneumatic latch and the heavy-duty walkway absorbers allow easy access to the turntable and enable large UEs to be moved in and out of the chamber.

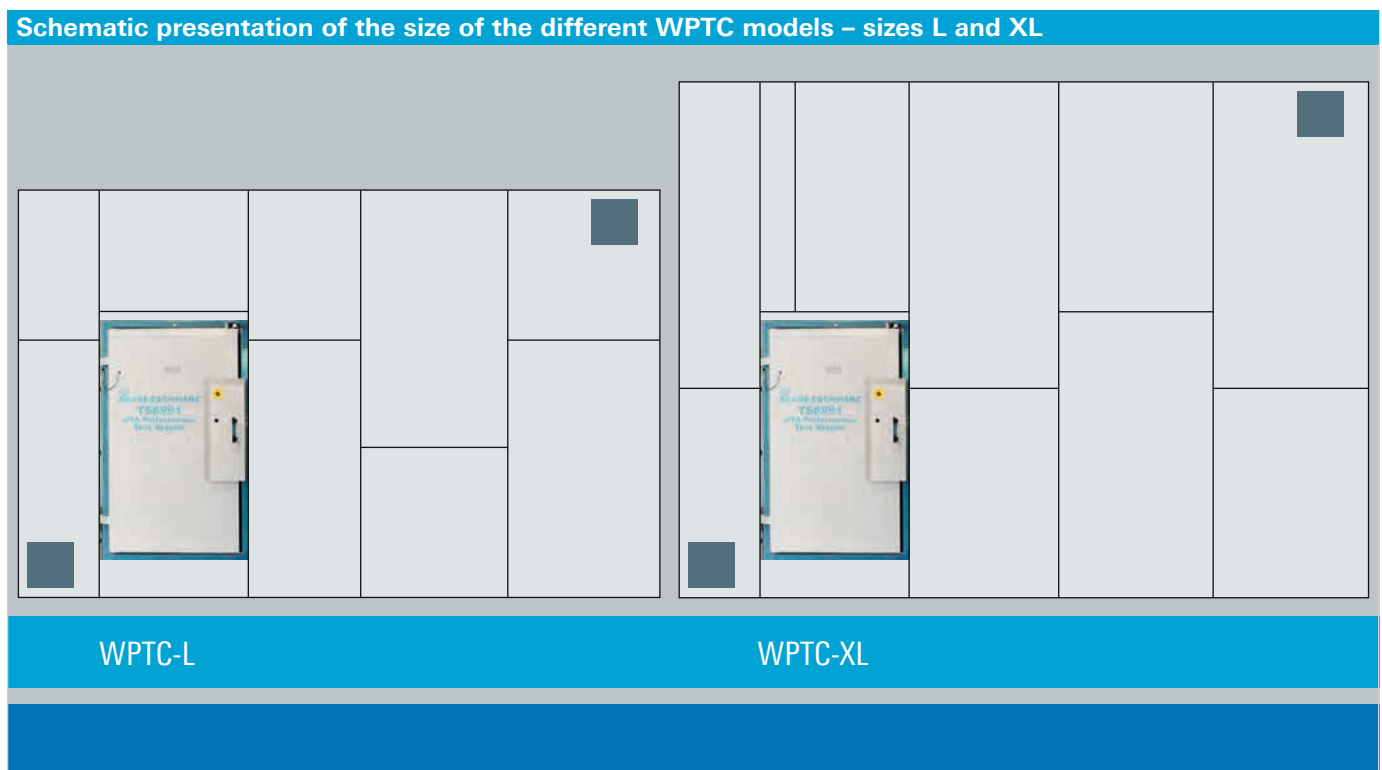
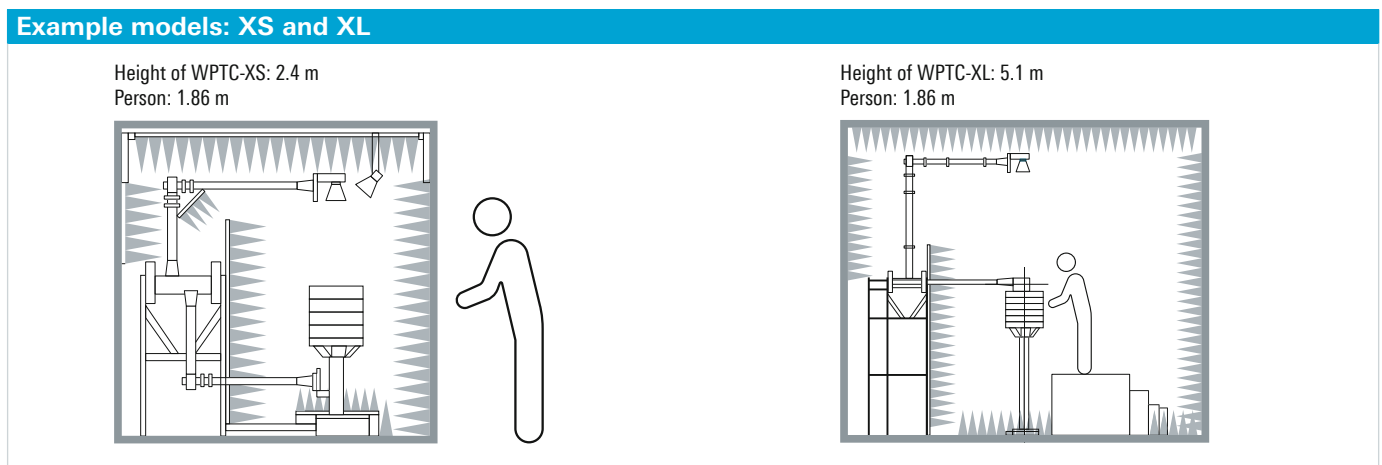

R&S®AMS32 OTA performance measurement software

R&S®AMS32 test results with 3D view.

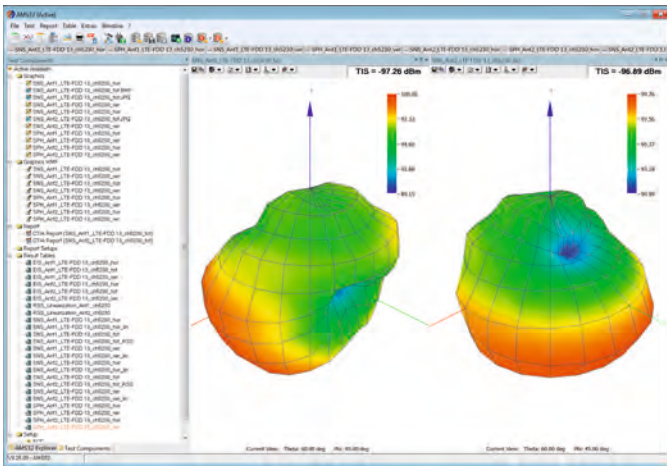

Ready-to-use test templates.

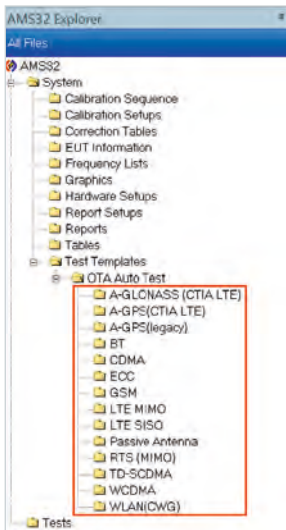

Test sequencer.

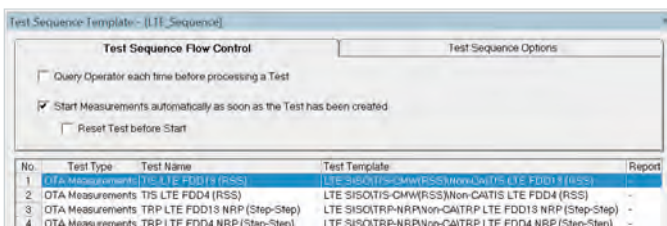

Automated measurements

In order to obtain automated, fast and accurate results, it is essential to have a measurement tool that is in constant communication with the positioning system as well as test and measurement equipment. It is crucial to have software that is flexible enough for pretesting and R&D and that is straightforward to use for product certification.

The R&S®AMS32 OTA performance measurement software provides a streamlined process flow, in-line graphical result displays and a comprehensive report tool.

Ready-to-use test templates

Industry, network operator and custom test cases can be easily configured by menu-driven, parametric setup of test templates. These templates have sufficient flexibility to improve speed and for customizations, but allow straightforward adjustment of the settings to comply with industry standards.

provides test templates for all common wireless standards.

Unique viewer and test sequencer

The full version of R&S®AMS32 can be installed on any Windows PC without the need for a license key/smart card. Measurement data can be visualized, manipulated and exported into various formats and reports.

The optional test sequencer enables sequential execution of test templates with little to no user interaction.

Simple extension: EMC measurements

The intuitive R&S®AMS32 system software is based on the same software platform as the market-leading R&S®EMC32 solution. Simple software and possible hardware extensions allow any OTA system to be upgraded to a precompliant EMC/RSE system to perform very quick pre-tests for spurious emissions, a common problem that goes undetected in R&D product phases.

Result documentation made easy: straightforward result display

The integrated report function of the R&S®AMS32 software compiles all measured data, such as graphical and numerical results, test environments, DUT data and hardware setup, in a single document. The obtained results are summarized in a standardized CTIA evaluation report. The report layout can be customized and the summary report file is stored in standard formats, e.g. *.csv, *.rtf or *.pdf.

Near-field far-field (NF-FF) transformation

The NF-FF transformation is a unique processing extension for R&S®AMS32 since it allows the use of passive near-field antenna measurements to derive accurate far-field results.

This approach, based on the Technical University of Munich's fast irregular antenna field transformation algorithm (FIAFTA), supports full probe correction and delivers excellent flexibility and accuracy through the use of arbitrary probes and irregular sampling grids.

Modular technology options

R&S®AMS32 is updated frequently to incorporate customer feedback and new features from industry and network operator test plans. Existing and new options are typically offered in a modular fashion to reduce the number of licenses and to bundle common features in technology bundles. In order to offer a cost-effective R&S®DST200 diagnostic chamber for OTA purposes, a slightly different licensing scheme has been introduced than for the WPTC-based systems.

Optimized test times

R&S®AMS32 has been optimized for ease of use and scalability to improve time to market of new and important features and test times. Typical test times for CTIA compliant test cases are summarized below.

Modular technology options	
R&S®AMS32 antenna measurement software Basic package including functionalities: passive antenna measurements, range calibration and site ripple test	
R&S®AMS32-K22 GSM/GPRS/EDGE technology	R&S®AMS32-K23 CDMA2000® 1xRTT/1xEV-DO technology
R&S®AMS32-K24 WCDMA/HSPA technology	R&S®AMS32-K25 WLAN/Bluetooth® technologies
R&S®AMS32-K271 TD-SCDMA technology (R&S®CMW500)	R&S®AMS32-K28 Legacy A-GPS (GSM, WCDMA, CDMA) technology
R&S®AMS32-K29 Basic LTE SISO technology	R&S®AMS32-K30 Enhanced LTE SISO technology (-K29 + synchronized ECC and 2 DL CA)
R&S®AMS32-K30A Advanced LTE SISO technology (LTE-U, 3 DL CA)	R&S®AMS32-K33 LTE A-GNSS technology per CTIA
R&S®AMS32-K33V LTE A-GPS per Verizon	R&S®AMS32-K50/-K51/-K52 NF-FF transformation, probe correction

Typical test times

Measurement	Test mode	Test time
Efficiency	spiral scan	1 min to 2 min for broadband frequency sweep
TRP (cellular)	stepped	approx. 5 min/ch
TRP (cellular)	spiral scan	approx. 1 min/ch
TRP (WLAN)	spectrum analyzer	8 min/ch
TRP (WLAN)	R&S®CMW500	15 min/ch
TIS (cellular)	RSS-based	6 min/ch
TIS (CDMA)	classical	45 min/ch
TIS (WLAN)	R&S®CMW500	15 min/ch

Modular technology options for the R&S®DST200	
R&S®AMS32-DST antenna measurement software Basic package tailored for R&S®DST200	
R&S®AMS32-PK20 GSM/WCDMA/CDMA/LTE technologies	R&S®AMS32-PK25 GSM/WCDMA/CDMA/LTE/TD-SCDMA/ WLAN/Bluetooth® technologies
R&S®AMS32-K25 WLAN/Bluetooth® technologies	R&S®AMS32-K271 OTA module for TD-SCDMA technology (R&S®CMW500)
R&S®AMS32-K28 Legacy A-GPS (GSM, WCDMA, CDMA) technologies	R&S®AMS32-PK25 Advanced LTE SISO technology (LTE-U, 3CC CA)
R&S®AMS32-K25 LTA A-GNSS technology per CTIA	R&S®AMS32-K33V LTA A-GPS per Verizon

Cellular OTA testing

The majority of today's active OTA testing is based on cellular technologies with signaling measurements and follows test plans from CTIA and 3GPP. For these tests, the R&S®CMW500 communication analyzer emulates a base station (BS) that the UE is connected to during an active call. The link that is not tested is generally routed over a link antenna integrated into the pedestal/turntable, which turns with the UE during the test. With this setup, the link is very stable during the measurement, vastly reducing communications issues such as dropped calls.

TRP measurements with simultaneous EIRP measurements

For TRP measurements, the uplink performance (from the UE to the BS) is most efficiently characterized with a set of R&S®NRP power sensors, while the R&S®CMW500 communicates with the UE in uplink and downlink over the link antenna. The use of power sensors allows the simultaneous measurement of EIRPs for the two principal polarizations (theta/phi or H/V) with a very straightforward and cost-effective setup.

TRP measurements using two antenna arms

If a second antenna arm is added, the test times for TRP can be significantly improved since one antenna with its set of power sensors can measure the upper hemisphere while the second antenna with its set of power sensors simultaneously measures the lower hemisphere. Generally, the test time is reduced by a factor of two.

TRP and EIRP measurements

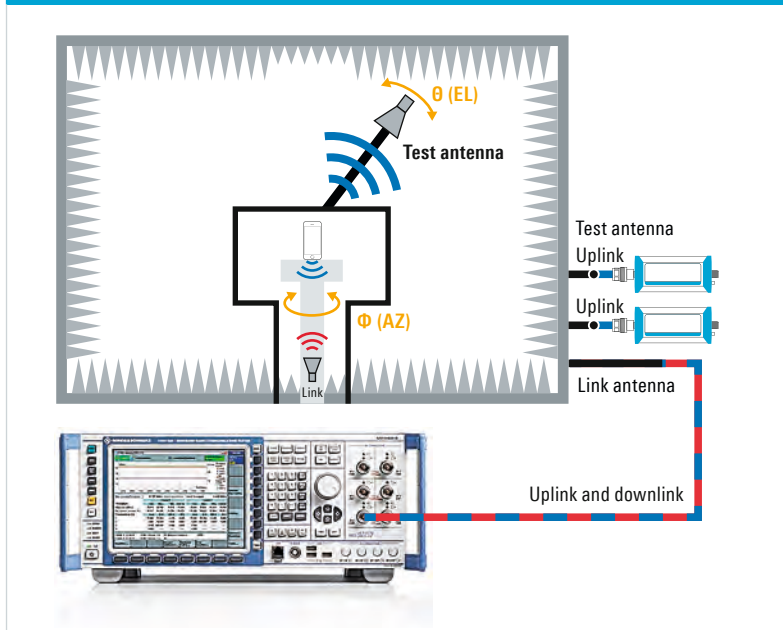

TRP measurements using two antenna arms

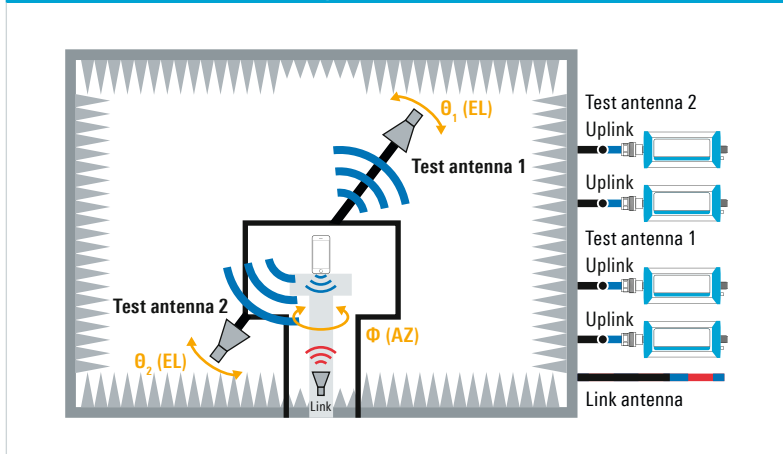

TIS measurements

For TIS measurements, the downlink performance (from the BS to the UE) is characterized over the test antenna path with the R&S®CMW500, while the uplink is established over the constant link antenna path.

CA measurements

More recently, carrier aggregation (CA) test cases have been introduced in CTIA test plans. The initial focus has been on 2 DL CA with a single uplink carrier followed by 3 DL CA with a single uplink carrier. Small software and hardware changes in the R&S®TS8991 setup allow straightforward upgrading to support any of the required CA test cases. A sample setup to perform TIS/EIS measurements on the secondary component carrier (SCC) is shown below. The SCC DL is characterized over the test antenna path with the R&S®CMW500, while the PCC uplink and downlink are established over the constant link antenna path.

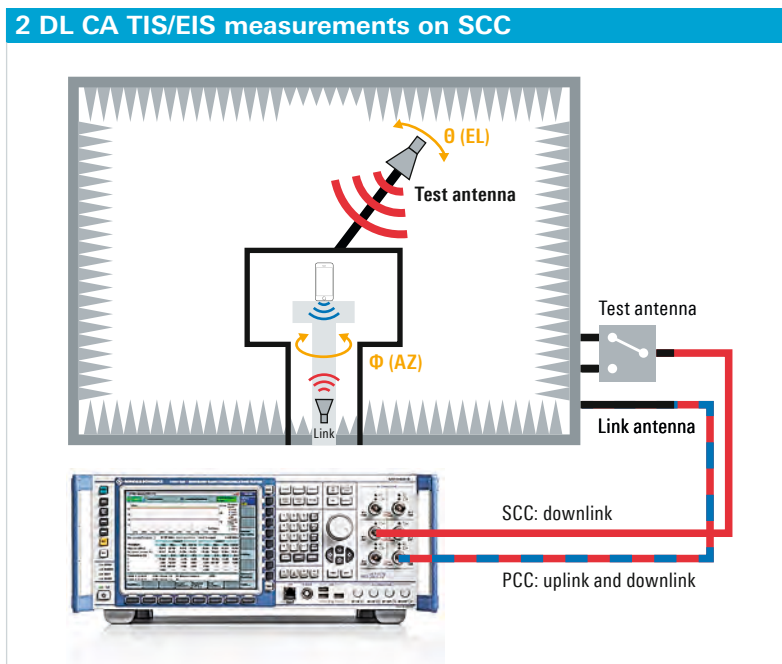
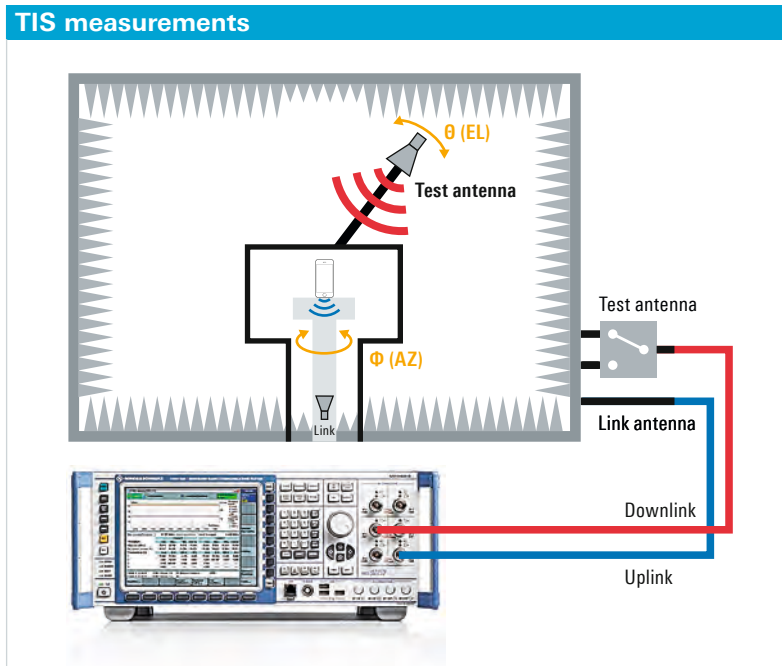

Non-cellular OTA testing

In addition to cellular TRP&TIS/TRS tests, the R&S®TS8991 supports various non-cellular technologies. Very simple and cost-effective upgrades to existing OTA systems provide support of technologies such as A-GNSS, WLAN and Bluetooth®. The key enabler for non-cellular testing is the R&S®CMW500.

Assisted global navigation satellite system (A-GNSS) testing

Compared to standalone GNSS, e.g. GPS, Glonass, Galileo, etc., assisted GNSS (A-GNSS) reduces the time to calculate the position of a wireless device ("fix"). In addition to satellite information, A-GNSS uses information from a base station, such as accurate cell coordinates and almanac data. Service providers need to deliver fast and reliable location information even under poor satellite signal conditions, e.g. to meet the emergency service requirements (E911).

CTIA has standardized the test procedures for A-GPS OTA performance for GSM, CDMA, WCDMA as well as LTE. These procedures also include test cases for hybrid A-GPS and A-Glonass scenarios. The communications protocol (LPP or RRLP) used varies depending on the wireless communications standard in use and potentially the bearer (C-Plane or U-Plane) being used to transport the assistance data.

A-GNSS TIS measurements

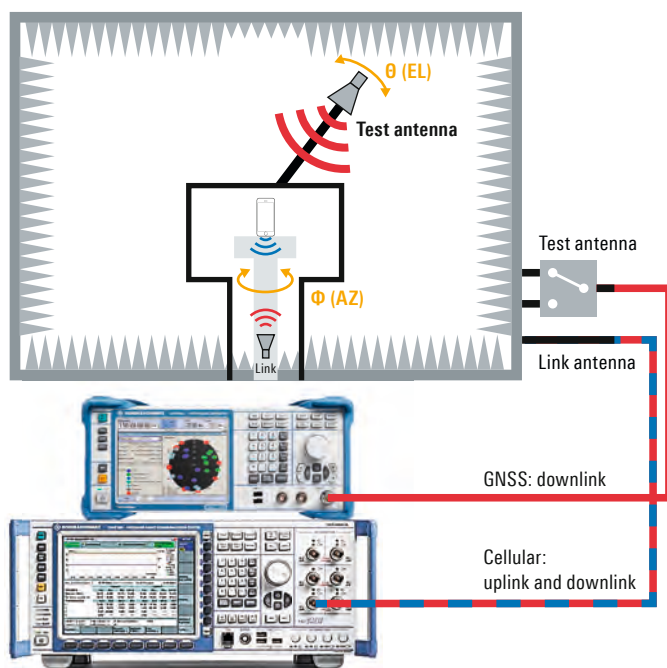

All CTIA-defined A-GNSS test cases are supported by the R&S®TS8991 system by adding the R&S®SMBV100A satellite simulator to the R&S®CMW500 with the respective technology options and corresponding R&S®AMS32 software modules.

The schematic setup of these important test cases is shown on the left. The GNSS scenario is introduced over the test antenna and the A-GNSS performance of the UE is characterized by changing the power levels of the simulated satellites. The cellular sidelink in uplink and downlink is established over the link antenna.

A-GNSS capabilities		
Wireless standard	A-GNSS	Software option
GSM, CDMA, WCDMA	A-GPS	R&S®AMS32-K28
LTE (LPP, RRLP)	A-GPS, hybrid A-GPS and A-Glonass	R&S®AMS32-K33

WLAN testing

WLAN and the coexistence of cellular technologies with WLAN and vice versa has been specified in the “Test Plan for RF Performance Evaluation of Wi-Fi Mobile Converged Devices” developed jointly by the CTIA and the Wi-Fi Alliance.

Specific R&S®CMW500 upgrade options, the addition of uplink/downlink amplification in the system paths and the R&S®AMS32-K25 software options are necessary to upgrade an existing R&S®TS8991 system to support all IEEE 802.11a/b/g/n test cases for mobile stations and access points.

To reduce test time and achieve a larger dynamic range, a spectrum analyzer with sufficient analysis bandwidth is recommended.

Bluetooth® testing

Even though Bluetooth® OTA testing has not yet been standardized, the R&S®TS8991 system already supports Bluetooth®.

Similar to WLAN, just a couple of R&S®CMW500 options, uplink/downlink amplification in the system paths and the R&S®AMS32-K25 software options are necessary to support Bluetooth® OTA testing.

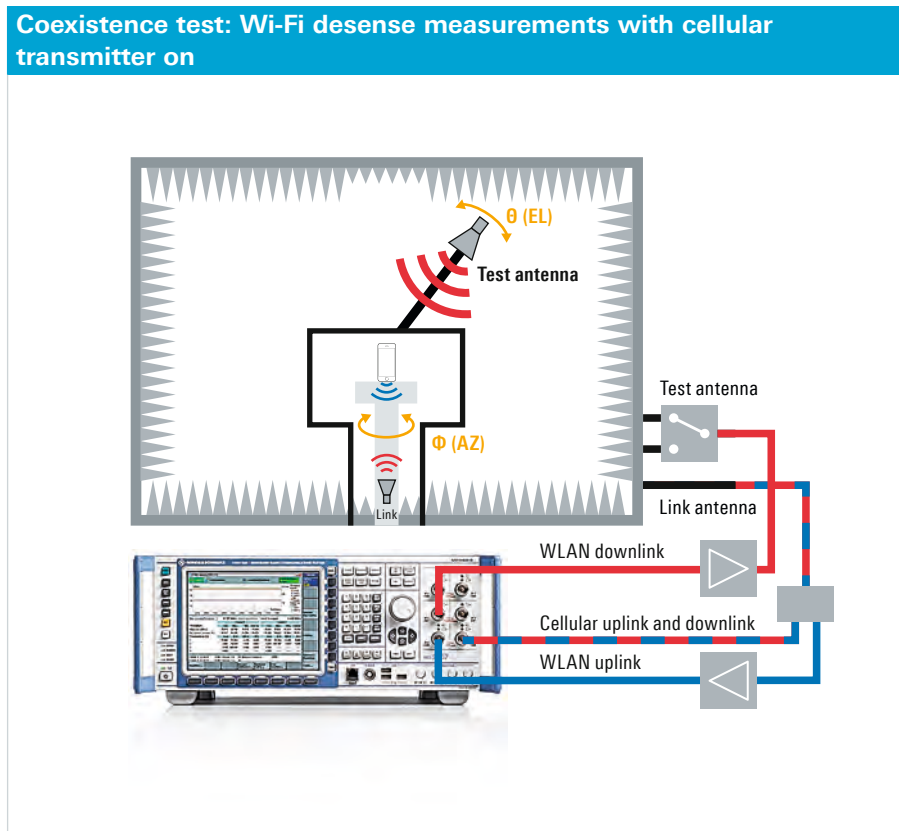

Specifications in brief

Specifications in brief		
OTA measurements	according to CTIA and 3GPP standards	TRP, TIS/TRS, intermediate channel
	general	passive antenna measurements
Frequency range	depends on system configuration	400 MHz to 18 GHz
	passive antenna measurements	expandable on request
DUT positioner		
Conical cut positioner		depends on WPTC chamber dimensions
Max. DUT load	light duty	23 kg
	heavy duty	100 kg
Azimuth range		360°
Elevation range		±165°
Positioning accuracy	both axes	< 0.5° ¹⁾
Distance antenna to DUT		0.65 m to 1.83 m (see WPTC model overview table)
Supply voltage	CCP positioner	380 V to 400 V, 50 Hz, three-phase, 16 A; 208 V, 60 Hz, three-phase, 32 A (USA)
	R&S®TS8991 system rack	100 V to 240 V, 50/60 Hz; max. 2.5 kVA, depending on configuration
Remote control interfaces		LAN, GPIB (IEEE 488.2), USB 2.0
General data		
Temperature	operating temperature range	+20 °C to +26 °C
	storage temperature range	0 °C to +40 °C
Relative humidity		20% to 80 %, non-condensing
Dimensions WPTC chamber (W × H × D, outside of RF shielding)	WPTC-XS	2.43 m × 2.40 m × 2.43 m (7.97 ft × 7.87 ft × 7.97 ft)
	WPTC-S	3.70 m × 3.00 m × 3.10 m (12.14 ft × 9.84 ft × 10.17 ft)
	WPTC-M	4.60 m × 3.45 m × 3.70 m (15.09 ft × 11.32 ft × 12.14 ft)
	WPTC-L	5.20 m × 4.05 m × 4.30 m (17.06 ft × 13.29 ft × 14.11 ft)
	WPTC-XL	5.80 m × 5.10 m × 5.20 m (19.03 ft × 16.73 ft × 17.06 ft)
Dimensions R&S®TS8991 system rack (W × H × D)		600 mm × 1965 mm × 900 mm (23.6 in × 77.4 in × 35.4 in)
Rack weight	depends on configuration	max. 220 kg (485.0 lb)

¹⁾ Higher accuracy on request.

Ordering information

Designation	Type	Order No.
OTA Performance Test System ¹⁾	R&S®TS8991	1119.4309.02
Software		
OTA Performance Measurement Software	R&S®AMS32	1508.6650.02
Option for GSM/GPRS/EDGE	R&S®AMS32-K22	1508.6680.22
Option for CDMA/CDMA2000	R&S®AMS32-K23	1508.6680.23
Option for WCDMA/HSPA	R&S®AMS32-K24	1508.6680.24
Option for WLAN/Bluetooth®	R&S®AMS32-K25	1508.6680.25
Option for TD-SCDMA	R&S®AMS32-K271	1508.6680.27
Option for A-GPS: GSM, CDMA, WCDMA	R&S®AMS32-K28	1508.6680.28
Option for LTE, SISO	R&S®AMS32-K29	1508.6680.29
Option for LTE, carrier aggregation, ECC	R&S®AMS32-K30	1508.6680.30
LTE, Advanced	R&S®AMS32-K30A	1508.6680.10
Option for A-GNSS: LTE	R&S®AMS32-K33	1508.6680.33
A-GPS LTE, VzW SIB8/16	R&S®AMS32-K33V	1508.6680.13
Triggered VNA Measurements	R&S®AMS32-K48	1508.6680.48
NF-FF Transformation	R&S®AMS32-K50	1508.6680.50
Probe Correction for NF-FF Transformation	R&S®AMS32-K51	1508.6680.51
Visualization of Equivalent Currents	R&S®AMS32-K52	1508.6680.52
OTA Measurement Software for R&S®DST200	R&S®AMS32-DST	1518.5270.02
R&S®AMS32 Software License Package for R&S®DST200	R&S®AMS32-PK20	1518.5286.02
R&S®AMS32 Software License Package 2 for R&S®DST200	R&S®AMS32-PK25	1508.5286.25
Test Sequencer for R&S®AMS32, R&S®EMC32, R&S®WMS32	R&S®EMC32-K11	1117.6862.02
Hardware		
RF Diagnostic Chamber	R&S®DST200	1510.9047.02
OTA RF Module, base version	R&S®OSP-B151	1522.4600.02
OTA RF Module, 1 × uplink and 1 × downlink amplifier	R&S®OSP-B151S	1522.4600.03
OTA RF Module, 2 × uplink and 2 × downlink amplifier	R&S®OSP-B151M	1522.4600.04
Upgrade Kit for R&S®OSP-B151, 1 × uplink and 1 × downlink amplifier	R&S®OSP-U151M	1522.4600.50

¹⁾ Project-specific configuration for R&S®TS8991 OTA test system and wireless performance test chambers (WPTC) required.

Архангельск (8182)63-90-72
Астана (7172)727-132
Астрахань (8512)99-46-04
Барнаул (3852)73-04-60
Белгород (4722)40-23-64
Брянск (4832)59-03-52
Владивосток (423)249-28-31
Волгоград (844)278-03-48
Вологда (8172)26-41-59
Воронеж (473)204-51-73
Екатеринбург (343)384-55-89
Иваново (4932)77-34-06

Ижевск (3412)26-03-58
Иркутск (395)279-98-46
Казань (843)206-01-48
Калининград (4012)72-03-81
Калуга (4842)92-23-67
Кемерово (3842)65-04-62
Киров (8332)68-02-04
Краснодар (861)203-40-90
Красноярск (391)204-63-61
Курск (4712)77-13-04
Липецк (4742)52-20-81
Киргизия (996)312-96-26-47

Магнитогорск (3519)55-03-13
Москва (495)268-04-70
Мурманск (8152)59-64-93
Набережные Челны (8552)20-53-41
Нижний Новгород (831)429-08-12
Новокузнецк (3843)20-46-81
Новосибирск (383)227-86-73
Омск (3812)21-46-40
Орел (4862)44-53-42
Оренбург (3532)37-68-04
Пенза (8412)22-31-16
Россия (495)268-04-70

Пермь (342)205-81-47
Ростов-на-Дону (863)308-18-15
Рязань (4912)46-61-64
Самара (846)206-03-16
Санкт-Петербург (812)309-46-40
Саратов (845)249-38-78
Севастополь (8692)22-31-93
Симферополь (3652)67-13-56
Смоленск (4812)29-41-54
Сочи (862)225-72-31
Ставрополь (8652)20-65-13
Казахстан (772)734-952-31

Сургут (3462)77-98-35
Тверь (4822)63-31-35
Томск (3822)98-41-53
Тула (4872)74-02-29
Тюмень (3452)66-21-18
Ульяновск (8422)24-23-59
Уфа (347)229-48-12
Хабаровск (4212)92-98-04
Челябинск (351)202-03-61
Череповец (8202)49-02-64
Ярославль (4852)69-52-93