

Беспроводные измерители мощности NRPM



Архангельск (8182)63-90-72
Астана (7172)727-132
Астрахань (8512)99-46-04
Барнаул (3852)73-04-60
Белгород (4722)40-23-64
Брянск (4832)59-03-52
Владивосток (423)249-28-31
Волгоград (844)278-03-48
Вологда (8172)26-41-59
Воронеж (473)204-51-73
Екатеринбург (343)384-55-89
Иваново (4932)77-34-06

Ижевск (3412)26-03-58
Иркутск (395)279-98-46
Казань (843)206-01-48
Калининград (4012)72-03-81
Калуга (4842)92-23-67
Кемерово (3842)65-04-62
Киров (8332)68-02-04
Краснодар (861)203-40-90
Красноярск (391)204-63-61
Курск (4712)77-13-04
Липецк (4742)52-20-81

Киргизия (996)312-96-26-47

Магнитогорск (3519)55-03-13
Москва (495)268-04-70
Мурманск (8152)59-64-93
Набережные Челны (8552)20-53-41
Нижний Новгород (831)429-08-12
Новокузнецк (3843)20-46-81
Новосибирск (383)227-86-73
Омск (3812)21-46-40
Орел (4862)44-53-42
Оренбург (3532)37-68-04
Пенза (8412)22-31-16

Россия (495)268-04-70

Пермь (342)205-81-47
Ростов-на-Дону (863)308-18-15
Рязань (4912)46-61-64
Самара (846)206-03-16
Санкт-Петербург (812)309-46-40
Саратов (845)249-38-78
Севастополь (8692)22-31-93
Симферополь (3652)67-13-56
Смоленск (4812)29-41-54
Сочи (862)225-72-31
Ставрополь (8652)20-65-13

Казахстан (772)734-952-31

Сургут (3462)77-98-35
Тверь (4822)63-31-35
Томск (3822)98-41-53
Тула (4872)74-02-29
Тюмень (3452)66-21-18
Ульяновск (8422)24-23-59
Уфа (347)229-48-12
Хабаровск (4212)92-98-04
Челябинск (351)202-03-61
Череповец (8202)49-02-64
Ярославль (4852)69-52-93

<https://rohdeschwarz.nt-rt.ru> || rwz@nt-rt.ru

AT A GLANCE

The R&S®NRPM OTA power measurement solution is designed to calibrate the transmit antenna output power and test the beamforming function over the air.

5G, WLAN IEEE802.11ad, IEEE802.11ay and automotive radar use higher carrier frequencies and higher signal bandwidths in order to achieve very high data rates. This requires the use of phased array antennas in wireless devices and base stations. These antennas use beamforming to control the direction of radiation of the transmit antenna, thus maximizing the power level at the receiver.

Free-space propagation loss and diffraction loss increase when data is transmitted at high frequencies. To counteract these physical effects and nevertheless achieve the desired data rates, beamforming is used to optimally direct the phased array antenna beam. Since this antenna (DUT) features high integration density and has no RF connectors, it is not possible to access its transmit signal via cable. The DUT transmit power is measured over the air during the production of wireless devices, base stations and RF modules. The antenna beamforming performance must also be verified; this is done using antennas that are spatially distributed.

The R&S®NRPM OTA power measurement solution is ideal for these measurements. It supports the frequency range from 18 GHz to 90 GHz, covering the 5G NR frequency band, the 57 GHz to 66 GHz band defined for WLAN IEEE802.11ad and frequencies above 66 GHz for WLAN IEEE802.11ay. Furthermore, the automotive radar range from 76 GHz to 81 GHz is covered.

The fully calibrated R&S®NRPM antenna modules, a Vivaldi antenna with an integrated diode detector, measure the power directly at the receive antenna. The number of antenna modules can be selected to scale the system to meet different test requirements. The economical base configuration with one antenna module measures the power of the incident wave from the DUT to the antenna module. More antenna modules can be added to test the beamforming function.

R&S®NRPM OTA power measurement solution with R&S®NRPM-A90D dual-polarized antenna module for use with a shielded RF test box

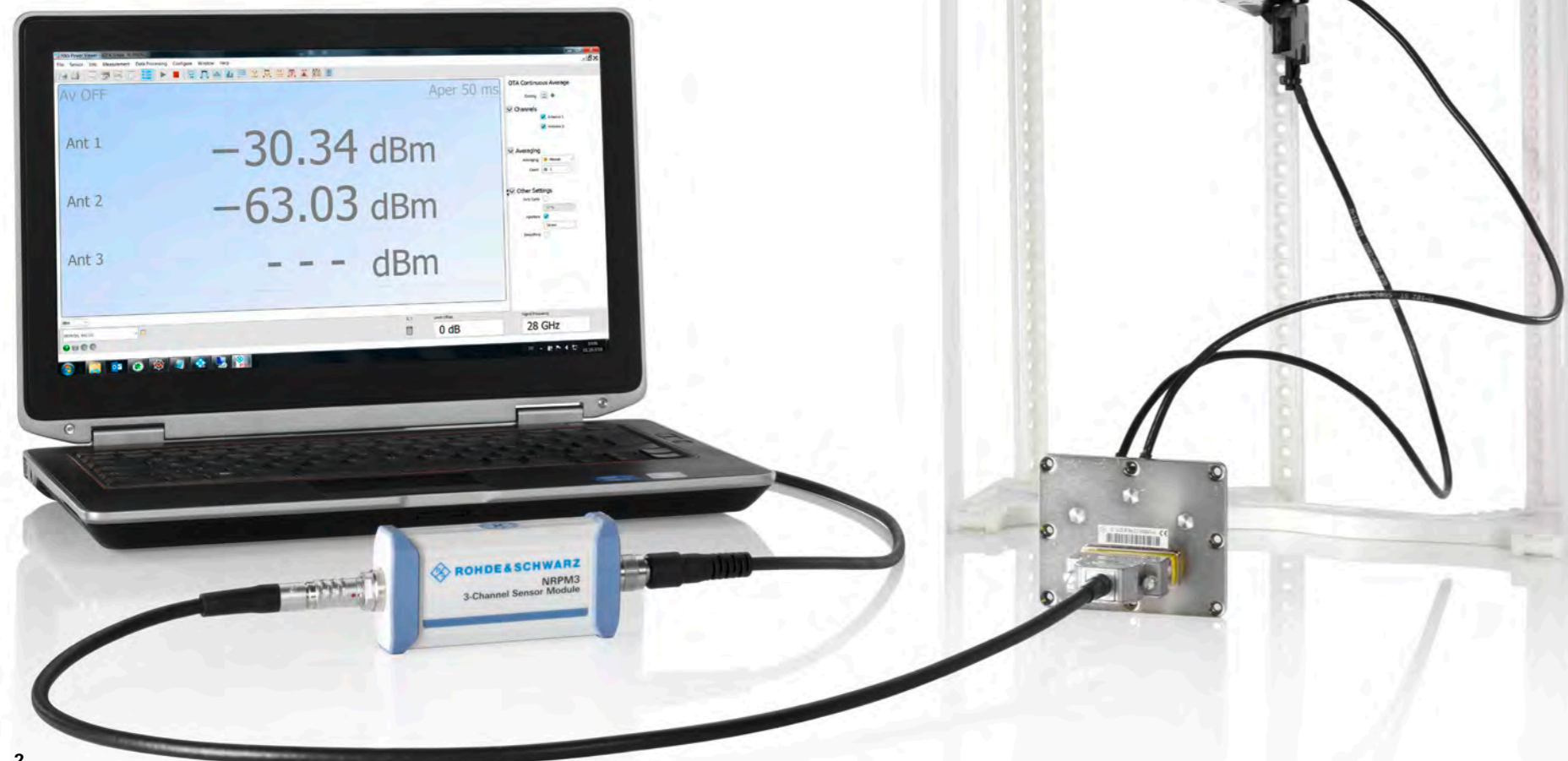

BENEFITS

Key features

- ▶ Very high sensitivity
- ▶ Fully calibrated system with specified system uncertainty
- ▶ Low-reflection antenna module
- ▶ Key facts
- ▶ [page 4](#)

Solution components

- ▶ Single-polarized antenna module
- ▶ Dual-polarized antenna module
- ▶ Filtered cable feedthrough
- ▶ Interface module for benchtop application
- ▶ Three-channel sensor module
- ▶ Measuring and monitoring with R&S®Power Viewer Plus software
- ▶ Scalable to customer requirements
- ▶ Compact test setup with R&S®TS7124 shielded RF test box

▶ [page 5](#)

Test applications

- ▶ General OTA power calibration
- ▶ System calibration for OTA receiver tests
- ▶ TX antenna gain calibration
- ▶ TX beamforming verification

▶ [page 9](#)

KEY FEATURES

A conventional setup for OTA power measurement consists of many different components: horn antennas, waveguide-to-coax adapters, RF cables and power sensors. When all these components are joined together in a measuring system, system properties such as the lower test limit and measurement accuracy are affected by mismatches, attenuation losses, reflections and frequency-dependent antenna gain.

The R&S®NRPM OTA power measurement solution offers considerable advantages compared with a conventional setup, mainly due to the antenna module. For instance, the antenna module consists of a low-reflection antenna and a diode detector integrated directly on the antenna for power measurement. Additional RF components and RF cables are not needed. The antenna module is fully calibrated over the entire frequency and signal level range, eliminating many potential problems for users. Unlike horn antennas, which only cover a limited frequency range, the antenna module is extremely wideband, allowing the entire 5G spectrum (for example) from 24.5 GHz to 43.5 GHz to be covered with just one setup.

Very high sensitivity

At high frequencies, OTA power measurements capture very low power levels due to strong free-space propagation losses. The R&S®NRPM OTA power measurement solution therefore uses a highly sensitive diode detector, which is integrated directly on the antenna, for power measurement. An additional RF cable, which would further attenuate the signal to be measured, is not necessary. The R&S®NRPM-A90 and R&S®NRPM-A90D antenna modules are therefore able to measure power down to -76 dBm. For example, a DUT with a transmit power of -10 dBm can be positioned at a distance of 1 m, and the received power at the antenna module can still be determined precisely.

Fully calibrated system with specified system uncertainty

With conventional OTA measuring systems, a large part of the measurement uncertainty stems from frequency-dependent antenna gain and antenna pattern and from the use of mismatched RF components. By measuring power directly at the antenna, the R&S®NRPM OTA power measurement solution avoids this problem because it does not need any additional RF components. Moreover, the antenna gain, the antenna pattern and the diode detector are calibrated together. The phase center is also measured precisely. This is the only possible way to specify the measurement accuracy for the entire system. Complicated system calibration by the user is not necessary.

For more details, see also “Minimize measurement uncertainty for EIRP OTA measurements” application card (PD 3608.2871.92).

Low-reflection antenna module

The R&S®NRPM-A90 and R&S®NRPM-A90D antenna modules have a very low radar cross section, which is about 10 dB below the value of a horn antenna with comparable gain. This makes them ideally suited for use in a shielded environment, due to the virtual absence of reflections.

Key facts

- ▶ 5G, WLAN IEEE802.11ad, IEEE802.11ay and automotive radar
- ▶ Frequency range from 18 GHz to 90 GHz
- ▶ Ideal for beamforming tests
- ▶ Fully calibrated antenna module with integrated diode detector
- ▶ Scalable to customer requirements
- ▶ Fits perfectly into shielded RF test box

Measured quantities

- ▶ Equivalent isotropically received power P_{ISO} in W or dBm
- ▶ Power density S in W/m^2
- ▶ Electric field strength E_{eff} in V/m
- ▶ Magnetic field strength H_{eff} in A/m
- ▶ Power at the internal RF detector in W or dBm

SOLUTION COMPONENTS

Components of the R&S®NRPM OTA power measurement solution

- ▶ R&S®NRPM-A90 single-polarized antenna module
- ▶ R&S®NRPM-A90D dual-polarized antenna module
- ▶ R&S®NRPM-ZD3 filtered cable feedthrough for shielded RF test box
- ▶ R&S®NRPM-Z3 interface module for benchtop application
- ▶ R&S®NRPM3 three-channel sensor module

Monitoring and operation can be performed by connecting the R&S®NRPM3 sensor module to a laptop/PC via R&S®NRP-ZKU USB interface cable (available as accessories).

Single-polarized antenna module

The R&S®NRPM-A90 is a low-reflection, single-polarized Vivaldi antenna with an integrated diode detector for power measurements. The unique antenna module measures the power directly at the antenna. There is no need for extra RF cables. Unlike conventional systems, there is no cable loss to be compensated between the antenna and the power sensor. This significantly simplifies measurements.

To ensure accurate transmit power measurements, the frequency response of the antenna module is determined during production, and the correction values are stored in the antenna module. This data is used during measurements to correct the frequency response, making it possible to measure absolute power with high accuracy. The power sensor's high linearity even allows relative power to be measured with an uncertainty of < 0.1 dB.

Dual-polarized antenna module

The R&S®NRPM-A90D consists of two low-reflection, single-polarized Vivaldi antennas with an integrated diode detector, precisely arranged at a right angle. The reference boresight is in the geometric center of the antenna module. This allows measurement in both polarization directions. Consisting of two antennas, this antenna module uses two separate measurement channels.

Filtered cable feedthrough

The R&S®NRPM-ZD3 filtered cable feedthrough combines up to three antenna modules into one connector. From the cable feedthrough, three independent antenna measurements are taken to the R&S®NRPM3 sensor module via the R&S®NRPM-ZKD3 interface cable. The filtered cable feedthrough was developed for use with a shielded RF test box, e.g. R&S®TS7124.



R&S®NRPM-A90 single-polarized antenna module



R&S®NRPM-A90D dual-polarized antenna module



R&S®NRPM-ZD3 filtered cable feedthrough for a shielded RF test box

Interface module for benchtop application

For operation without a shielded RF test box, an R&S®NRPM-Z3 interface module is used. To avoid additional cables, the R&S®NRPM-Z3 is directly plugged onto the R&S®NRPM3 three-channel sensor module and can host up to three R&S®NRPM-A90 antenna modules.

Three-channel sensor module

The R&S®NRPM3 three-channel sensor module processes the measured values from up to three antenna modules in three separate channels. If more than three antenna modules are needed, more sensor modules can be added. The R&S®NRPM3 is connected to a control PC by means of an R&S®NRP-ZKU USB interface cable.



R&S®NRPM-Z3 three-channel interface module



R&S®NRPM3 three-channel sensor module



R&S®NRPM-Z3 interface module plugged onto the R&S®NRPM3 three-channel sensor module

Measuring and monitoring with R&S®Power Viewer Plus software

The free-of-charge R&S®Power Viewer Plus software runs on a laptop/PC and performs continuous average power measurements or trace measurements for each antenna module. The software supports up to four sensor modules and displays the results for up to twelve R&S®NRPM-A90 or six R&S®NRPM-A90D antenna modules simultaneously.

Scalable to customer requirements

The R&S®NRPM OTA power measurement solution is scalable and configurable, enabling customers to tailor their setups as required for the test application and the DUT. The system configuration depends on the required number of antenna modules. Measurement results can be easily queried and processed using remote commands.

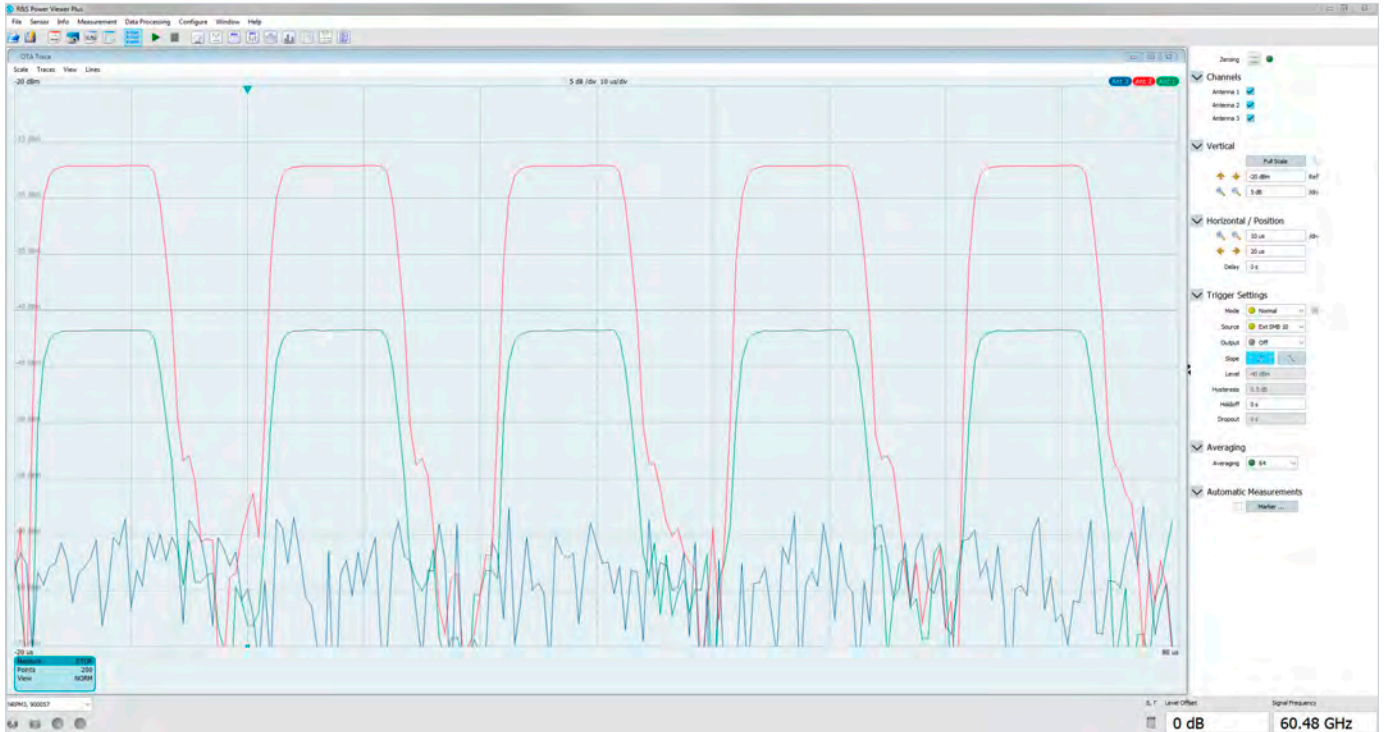

Trace measurement with R&S®Power Viewer Plus

Test setup with three antenna modules

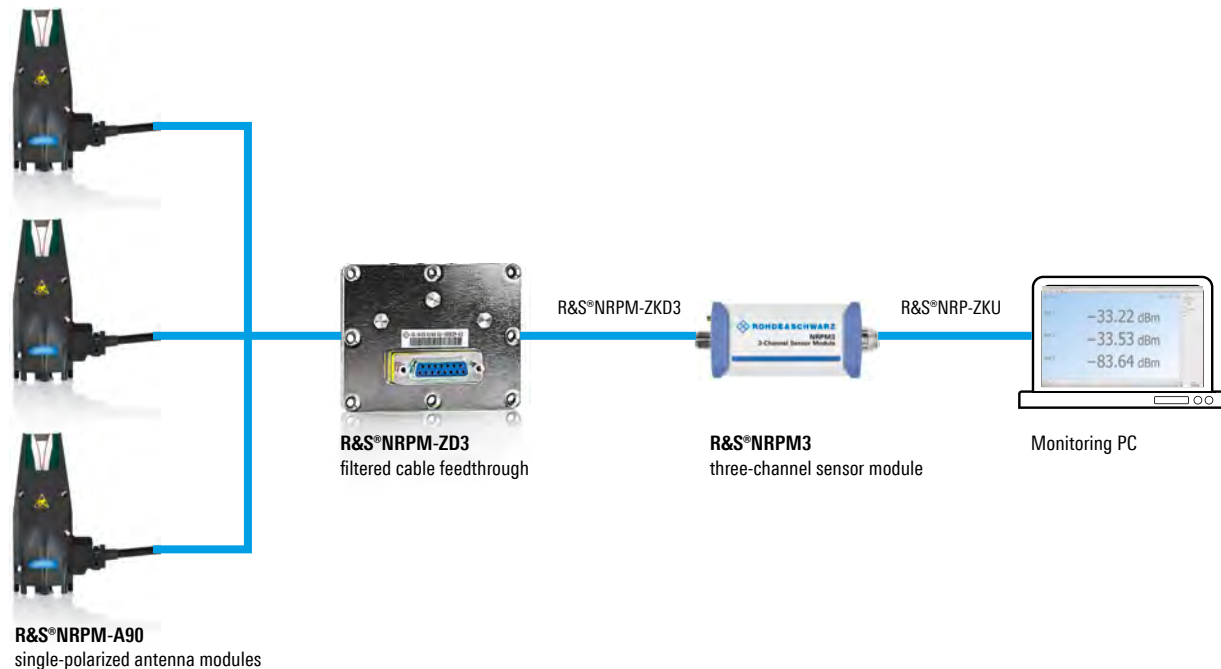

Compact test setup with R&S®TS7124 shielded RF test box

In a radiated power test setup, shielded boxes are essential for reliable measurements. The R&S®NRPM OTA power measurement solution in combination with the R&S®TS7124 shielded RF test box delivers measurements with a high degree of reproducibility in a very compact setup, whether in the lab or in production.

The antenna supporting ring inside the shielded RF test box offers a high degree of flexibility to position and align the antennas as required for a specific application. The R&S®TS7124 can be integrated into a 19" rack. Its rugged design ensures a long service life. Manual and automatic versions of the R&S®TS7124 are available.

Flexible mounting and alignment options

In the R&S®TS7124, the antennas can be mounted and positioned on an integrated antenna ring (half or full) specifically designed for that purpose. Wall mounting using an antenna holder is also possible.

A 45° adapter for lateral antenna tilts additionally allows flexible antenna alignment in a wide variety of directions.

All holders and adapters are made from nonreflective material:

- ▶ R&S®TS-F24-AH1 half antenna ring, 1525.8887.02
- ▶ R&S®TS-F24-AR full antenna ring, 1525.8906.02
- ▶ R&S®TS-F24-AH2 antenna holder, 1525.8893.02
- ▶ R&S®TS-F2X-VH4 45° adapter, 1525.8758.02

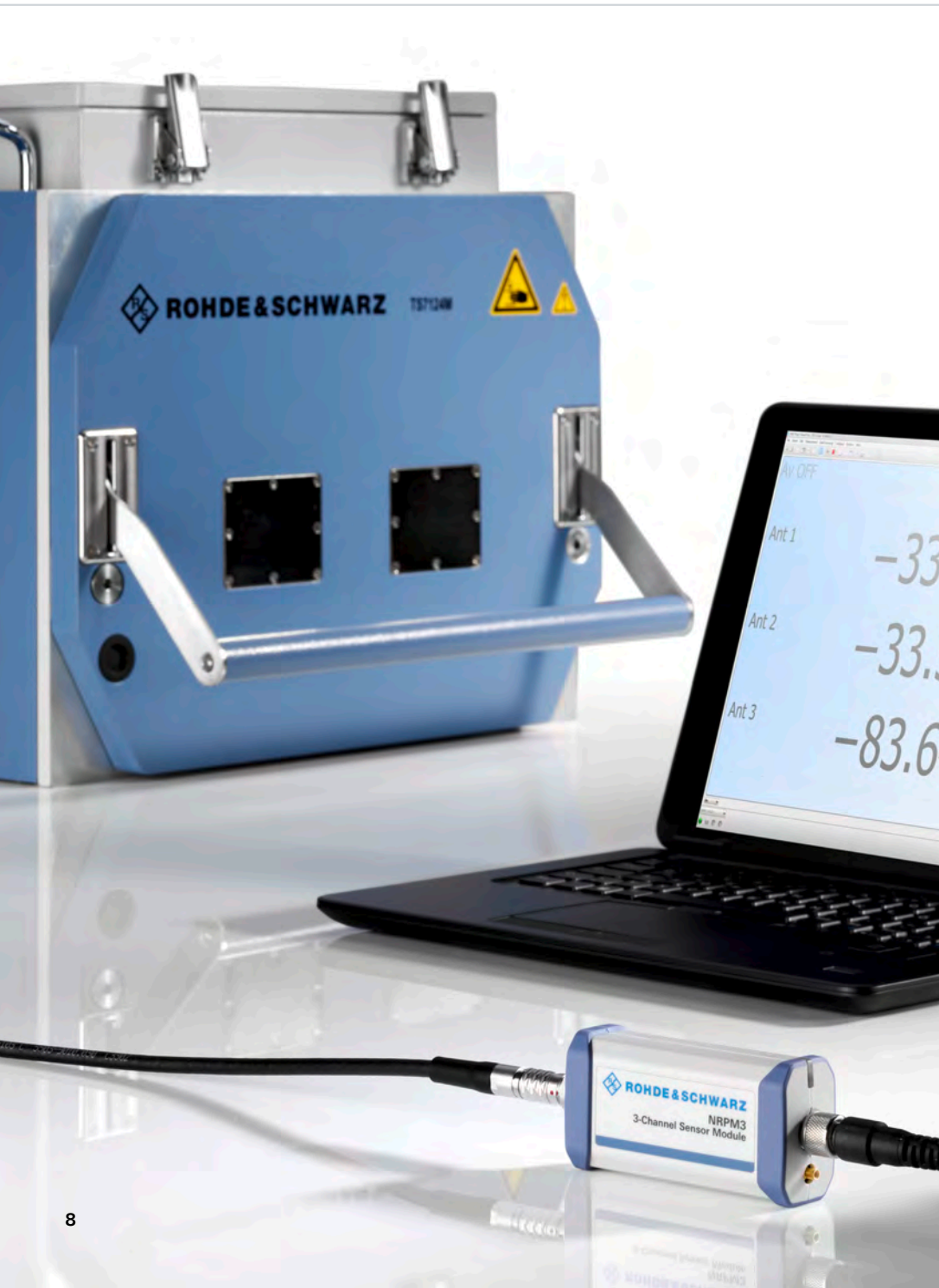

R&S®TS7124 shielded RF test box

TEST APPLICATIONS

General OTA power calibration

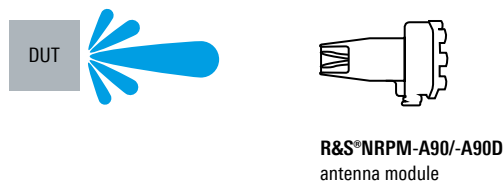

General OTA power calibration

The R&S®NRPM OTA power measurement solution in its basic configuration with one R&S®NRPM-A90 single-polarized antenna module or one R&S®NRPM-A90D dual-polarized antenna module measures power directly at the receive antenna. This measurement can be used to calibrate the absolute transmit power of the DUT.

System calibration for OTA receiver tests

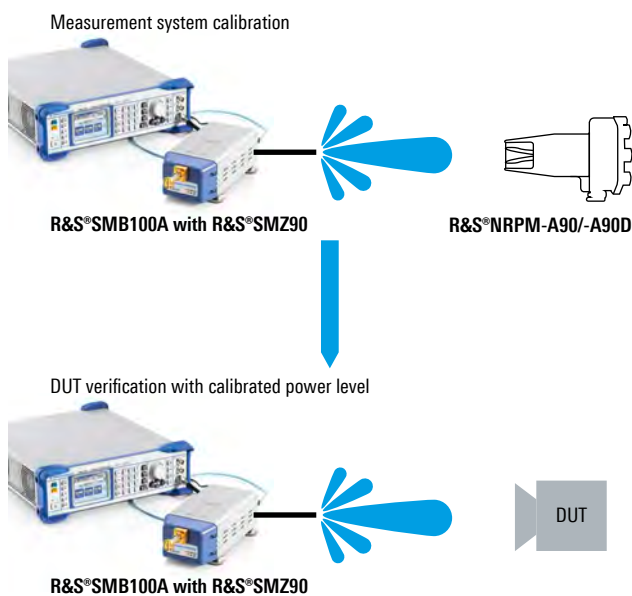

System calibration for OTA receiver tests

To test the receiver of the DUT, it is necessary to know the exact power at the DUT's position. To calibrate this measurement setup, the R&S®NRPM-A90 antenna module is positioned at the position of the DUT to calibrate the transmit power of the signal generator. The calibration is done with an R&S®NRPM-A90/-A90D antenna module, which is then replaced by the DUT. The exact receive power at the DUT's position is then known.

TX antenna gain calibration

When using phased array antennas, it is necessary to calibrate not only the antenna beam direction but also the antenna gain. Both tasks are covered by measuring the TX power with the R&S®NRPM-A90/-A90D antenna module while adjusting the phased array antenna.

TX beamforming verification

Multiple R&S®NRPM-A90/-A90D antenna modules are needed to test the beamforming function. If the antenna beam is directed at a specific antenna module, this module shows the highest average power of all antennas. Three antenna modules – arranged in a plane – are used to verify whether steering of the antenna beam in the horizontal plane functions properly. To additionally test the vertical beamforming function, the R&S®NRPM-A90/-A90D antenna modules must be arranged in at least two horizontal planes.

TX beamforming verification

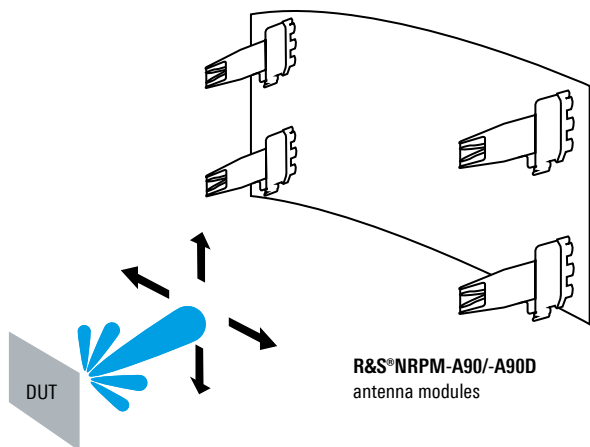

RECOMMENDED CONFIGURATIONS

	Type	Designation	Order No.	OTA power calibration ¹⁾	TX beamforming verification	
					With 3 antenna modules	With 4 antenna modules
Single-polarized						
Shielded chamber	R&S®NRPM-A90	single-polarized antenna module	1426.7760.xx ²⁾	1	3	4
	R&S®NRPM-ZD3	feedthrough module	1425.8786.02	1	1	2
	R&S®NRPM-ZKD3	interface cable	1425.8770.02	1	1	2
	R&S®NRPM3	sensor module	1425.8563.02	1	1	2
	R&S®NRP-ZKU	USB power sensor cable, length: 1.5 m	1419.0658.03	1	1	2
Benchtop	R&S®NRPM-A90	single-polarized antenna module	1426.7760.xx ²⁾	1	3	4
	R&S®NRPM-Z3	interface module	1426.7602.02	1	1	2
	R&S®NRPM3	sensor module	1425.8563.02	1	1	2
	R&S®NRP-ZKU	USB power sensor cable, length: 1.5 m	1419.0658.03	1	1	2
Dual-polarized						
Shielded chamber	R&S®NRPM-A90D	dual-polarized antenna module	1426.7777.xx ²⁾	1	3	4
	R&S®NRPM-ZD3	feedthrough module	1425.8786.02	1	2	3
	R&S®NRPM-ZKD3	interface cable	1425.8770.02	1	2	3
	R&S®NRPM3	sensor module	1425.8563.02	1	2	3
	R&S®NRP-ZKU	USB power sensor cable, length: 1.5 m	1419.0658.03	1	2	3
Benchtop	R&S®NRPM-A90D	dual-polarized antenna module	1426.7777.xx ²⁾	1	3	4
	R&S®NRPM-Z3	interface module	1426.7602.02	1	2	3
	R&S®NRPM3	sensor module	1425.8563.02	1	2	3
	R&S®NRP-ZKU	USB power sensor cable, length: 1.5 m	1419.0658.03	1	2	3

¹⁾ OTA power calibration:

- System calibration for OTA receiver tests
- TX antenna gain calibration

²⁾ Available with different cable lengths (see ordering information).

SPECIFICATIONS

Specifications

R&S®NRPM-A90 single-polarized antenna

Frequency range		18 GHz to 90 GHz
Power measurement range (frequency dependant)	continuous average	-76 dBm to -19 dBm
	trace	-63 dBm to -19 dBm
Rise/fall time		2.2 µs
Video bandwidth		220 kHz
Measurement uncertainty		
18 GHz to 24 GHz	absolute	0.68 dB to 0.81 dB
	relative	0.05 dB to 0.09 dB
> 24 GHz to 35 GHz	absolute	0.49 dB to 0.66 dB
	relative	0.05 dB to 0.09 dB
> 35 GHz to 57 GHz	absolute	0.50 dB to 0.72 dB
	relative	0.05 dB to 0.09 dB
> 57 GHz to 71 GHz	absolute	0.58 dB to 0.83 dB
	relative	0.05 dB to 0.09 dB
> 71 GHz to 81 GHz	absolute	0.61 dB to 0.91 dB
	relative	0.05 dB to 0.09 dB
> 81 GHz to 90 GHz	absolute	0.69 dB to 0.97 dB
	relative	0.05 dB to 0.09 dB

R&S®NRPM-A90D dual-polarized antenna

Frequency range		18 GHz to 90 GHz
Power measurement range (frequency dependant)	continuous average	-76 dBm to -19 dBm
	trace	-63 dBm to -19 dBm
Rise/fall time		2.2 µs
Video bandwidth		220 kHz
Measurement uncertainty (measurement distance 1 m)		
18 GHz to 24 GHz	absolute	0.73 dB to 0.85 dB
	relative	0.05 dB to 0.09 dB
> 24 GHz to 35 GHz	absolute	0.55 dB to 0.71 dB
	relative	0.05 dB to 0.09 dB
> 35 GHz to 57 GHz	absolute	0.59 dB to 0.78 dB
	relative	0.05 dB to 0.09 dB
> 57 GHz to 71 GHz	absolute	0.68 dB to 0.90 dB
	relative	0.05 dB to 0.09 dB
> 71 GHz to 81 GHz	absolute	0.72 dB to 0.99 dB
	relative	0.05 dB to 0.09 dB
> 81 GHz to 90 GHz	absolute	0.87 dB to 1.10 dB
	relative	0.05 dB to 0.09 dB

ORDERING INFORMATION

Designation	Type	Order No.
Three-channel sensor module, for R&S®NRPM-A90/-A90D antenna modules	R&S®NRPM3	1425.8563.02
Single-polarized antenna module, with integrated diode detector from 18 GHz to 90 GHz	R&S®NRPM-A90	1426.7760.xx
Cable length: 0.55 m		1426.7760.02
Cable length: 0.75 m		1426.7760.03
Cable length: 1.00 m		1426.7760.04
Cable length: 1.50 m		1426.7760.05
Dual-polarized antenna module, with integrated diode detector from 18 GHz to 90 GHz	R&S®NRPM-A90D	1426.7777.xx
Cable length: 0.55 m		1426.7777.02
Cable length: 0.75 m		1426.7777.03
Cable length: 1.00 m		1426.7777.04
Cable length: 1.50 m		1426.7777.05
Accessories		
Filtered cable feedthrough, for anechoic chamber (e.g. R&S®TS7124 shielded RF test box)	R&S®NRPM-ZD3	1425.8786.02
Interface cable, connecting R&S®NRPM-ZD3 filtered cable feedthrough with R&S®NRPM3 sensor module	R&S®NRPM-ZKD3	1425.8770.02
Interface module, for operation without anechoic chamber	R&S®NRPM-Z3	1426.7602.02
USB interface cable, length: 0.75 m	R&S®NRP-ZKU	1419.0658.02
USB interface cable, length: 1.50 m	R&S®NRP-ZKU	1419.0658.03
USB interface cable, length: 3.00 m	R&S®NRP-ZKU	1419.0658.04
USB interface cable, length: 5.00 m	R&S®NRP-ZKU	1419.0658.05
Six-pole interface cable, length: 1.50 m	R&S®NRP-ZK6	1419.0664.02
Six-pole interface cable, length: 3.00 m	R&S®NRP-ZK6	1419.0664.03
Six-pole interface cable, length: 5.00 m	R&S®NRP-ZK6	1419.0664.04
Trigger cable to synchronize two R&S®NRPM3 sensor modules, SMB to SMB, length: 0.75 m	R&S®NRPM-ZKT	1425.8857.02
Sensor hub, R&S®NRPM-ZKT	R&S®NRP-Z5	1146.7740.02

Warranty		
R&S®NRPM3, R&S®NRPM-A90, R&S®NRPM-A90D		3 years
All other items		1 year
Options		
Extended warranty, one year	R&S®WE1	
Extended warranty, two years	R&S®WE2	Please contact your local sales office.
Extended warranty with calibration coverage, one year	R&S®CW1	
Extended warranty with calibration coverage, two years	R&S®CW2	

Архангельск (8182)63-90-72
Астана (7172)727-132
Астрахань (8512)99-46-04
Барнаул (3852)73-04-60
Белгород (4722)40-23-64
Брянск (4832)59-03-52
Владивосток (423)249-28-31
Волгоград (844)278-03-48
Вологда (8172)26-41-59
Воронеж (473)204-51-73
Екатеринбург (343)384-55-89
Иваново (4932)77-34-06

Ижевск (3412)26-03-58
Иркутск (395)279-98-46
Казань (843)206-01-48
Калининград (4012)72-03-81
Калуга (4842)92-23-67
Кемерово (3842)65-04-62
Киров (8332)68-02-04
Краснодар (861)203-40-90
Красноярск (391)204-63-61
Курск (4712)77-13-04
Липецк (4742)52-20-81

Магнитогорск (3519)55-03-13
Москва (495)268-04-70
Мурманск (8152)59-64-93
Набережные Челны (8552)20-53-41
Нижний Новгород (831)429-08-12
Новокузнецк (3843)20-46-81
Новосибирск (383)227-86-73
Омск (3812)21-46-40
Орел (4862)44-53-42
Оренбург (3532)37-68-04
Пенза (8412)22-31-16

Пермь (342)205-81-47
Ростов-на-Дону (863)308-18-15
Рязань (4912)46-61-64
Самара (846)206-03-16
Санкт-Петербург (812)309-46-40
Саратов (845)249-38-78
Севастополь (8692)22-31-93
Симферополь (3652)67-13-56
Смоленск (4812)29-41-54
Сочи (862)225-72-31
Ставрополь (8652)20-65-13

Сургут (3462)77-98-35
Тверь (4822)63-31-35
Томск (3822)98-41-53
Тула (4872)74-02-29
Тюмень (3452)66-21-18
Ульяновск (8422)24-23-59
Уфа (347)229-48-12
Хабаровск (4212)92-98-04
Челябинск (351)202-03-61
Череповец (8202)49-02-64
Ярославль (4852)69-52-93

Киргизия (996)312-96-26-47

Россия (495)268-04-70

Казахстан (772)734-952-31

<https://rohdeschwarz.nt-rt.ru> || rwz@nt-rt.ru