

Анализатор источников сигнала DSA



Архангельск (8182)63-90-72
Астана (7172)727-132
Астрахань (8512)99-46-04
Барнаул (3852)73-04-60
Белгород (4722)40-23-64
Брянск (4832)59-03-52
Владивосток (423)249-28-31
Волгоград (844)278-03-48
Вологда (8172)26-41-59
Воронеж (473)204-51-73
Екатеринбург (343)384-55-89
Иваново (4932)77-34-06

Ижевск (3412)26-03-58
Иркутск (395)279-98-46
Казань (843)206-01-48
Калининград (4012)72-03-81
Калуга (4842)92-23-67
Кемерово (3842)65-04-62
Киров (8332)68-02-04
Краснодар (861)203-40-90
Красноярск (391)204-63-61
Курск (4712)77-13-04
Липецк (4742)52-20-81

Киргизия (996)312-96-26-47

Магнитогорск (3519)55-03-13
Москва (495)268-04-70
Мурманск (8152)59-64-93
Набережные Челны (8552)20-53-41
Нижний Новгород (831)429-08-12
Новокузнецк (3843)20-46-81
Новосибирск (383)227-86-73
Омск (3812)21-46-40
Орел (4862)44-53-42
Оренбург (3532)37-68-04
Пенза (8412)22-31-16

Россия (495)268-04-70

Пермь (342)205-81-47
Ростов-на-Дону (863)308-18-15
Рязань (4912)46-61-64
Самара (846)206-03-16
Санкт-Петербург (812)309-46-40
Саратов (845)249-38-78
Севастополь (8692)22-31-93
Симферополь (3652)67-13-56
Смоленск (4812)29-41-54
Сочи (862)225-72-31
Ставрополь (8652)20-65-13

Казахстан (772)734-952-31

Сургут (3462)77-98-35
Тверь (4822)63-31-35
Томск (3822)98-41-53
Тула (4872)74-02-29
Тюмень (3452)66-21-18
Ульяновск (8422)24-23-59
Уфа (347)229-48-12
Хабаровск (4212)92-98-04
Челябинск (351)202-03-61
Череповец (8202)49-02-64
Ярославль (4852)69-52-93

<https://rohdeschwarz.nt-rt.ru> || rwz@nt-rt.ru

AT A GLANCE

Only the highest signal quality ensures maximum throughput. The R&S® DSA DOCSIS® signal analyzer has been designed to support users by ensuring the highest signal quality. DOCSIS is the standard for transmitting IP data within hybrid fiber coaxial (HFC) cable TV networks. The new DOCSIS 3.1 standard supports unprecedented data rates, meeting the demand for increased data throughput.

The R&S® DSA allows precise, gapless signal analysis of DOCSIS 3.0, EuroDOCSIS 3.0 and DOCSIS 3.1 signals on the physical layer in realtime. A user can detect effects that degrade signal quality, e.g. ingress, reflections and laser clipping. With its dual receivers, the R&S® DSA analyzes downstream and upstream signals. The frequency spectrum and key signal characteristics are displayed in compact overviews and diagrams, providing conclusive information about the signal quality.

In addition to DOCSIS signals, the R&S® DSA can analyze digital TV signals such as J.83/A/B/C and DVB-C. Although IP data transfer is consuming more and more transmission capacity, digital TV transmission continues to play an important role in cable TV networks. The R&S® DSA can analyze digital TV, helping users ensure interference-free coexistence of DOCSIS and digital TV channels.

Convenient operation via the 10.1" touchscreen, intuitive pictograms and logically structured menus allow even less-experienced users to operate the instrument after a quick introduction.

Key facts

- ▶ Demodulation and analysis of DOCSIS 3.0/3.1 and EuroDOCSIS 3.0 downstream and upstream signals in realtime
- ▶ Demodulation and analysis of digital TV signals (J.83/A/B/C, DVB-C) in realtime
- ▶ Residual MER ≥ 50 dB with DOCSIS 3.1
- ▶ Residual MER ≥ 56 dB with SC-QAM
- ▶ Dual receivers for
 - Downstream (47 MHz to 1794 MHz)
 - Upstream (5 MHz to 204 MHz)
- ▶ Integrated spectrum analyzer
- ▶ 10.1" (25.6 cm) touchscreen
- ▶ Remote desktop function
- ▶ SCPI/SNMP remote control

Front view of the R&S® DSA

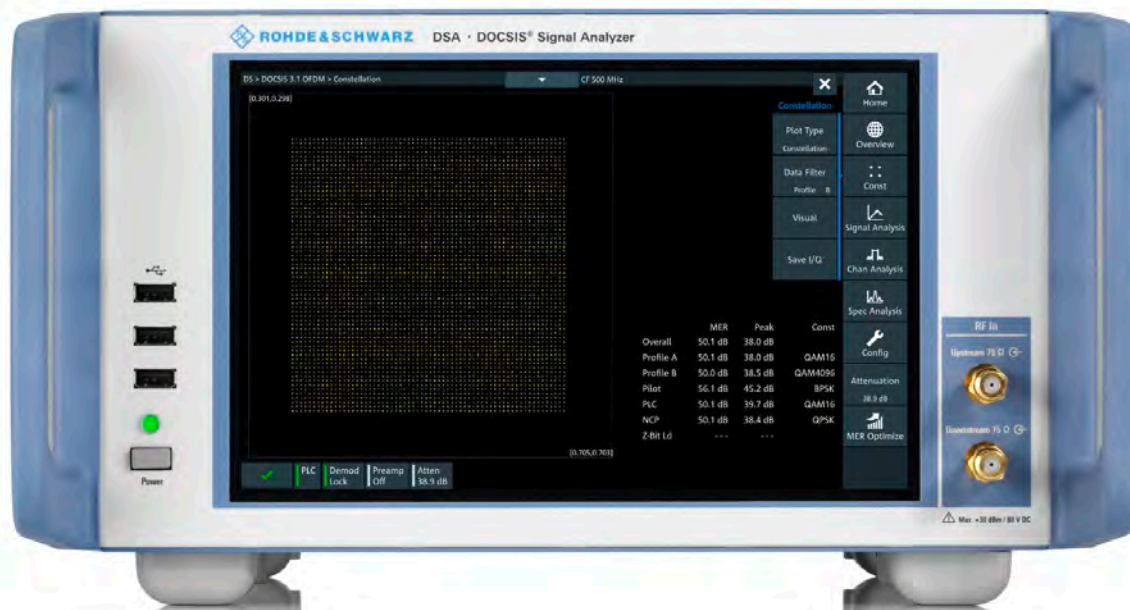

BENEFITS AND KEY FEATURES

Powerful, gapless DOCSIS downstream signal analysis

- ▶ FPGA based demodulation
- ▶ Realtime signal analysis
- ▶ Maximum performance
- ▶ Integrated spectrum analysis
- ▶ [page 4](#)

Detailed analysis of upstream signals

- ▶ Additional RF receiver for upstream signals (model .03)
- ▶ FPGA based realtime demodulation
- ▶ Detailed upstream analysis (R&S®DSA-K1500)
- ▶ Dynamic upstream signal analysis during live operation
- ▶ Upstream signal analysis with R&S®SFD
- ▶ Cable modem ranging test
- ▶ [page 6](#)

Digital TV signal analysis for interference-free parallel operation with DOCSIS

- ▶ FPGA based demodulation
- ▶ Realtime signal analysis
- ▶ [page 11](#)

Automatic channel measurements with R&S®TVSCAN 2.0

- ▶ Individual channel tables
- ▶ Verification in accordance with user-specific limits
- ▶ 2D and 3D visualization of measurement results
- ▶ [page 12](#)

Rear view of the R&S®DSA



POWERFUL, GAPLESS DOCSIS DOWNSTREAM SIGNAL ANALYSIS

DOCSIS 3.1 signals can be up to 192 MHz wide and consist of several thousand modulated single carriers. In extreme cases, the single carriers can be modulated with 4096QAM and higher. To take full advantage of DOCSIS 3.1, it is essential to know the quality of an HFC cable network, the components and the signals being transmitted, both at the cable headend and in the field.

This is also true when developing and producing network components such as cable modem termination systems (CMTS), line amplifiers, cable modems, electro-optical converters and modules for remote PHY.

Overview of R&S® DSA interfaces and function blocks

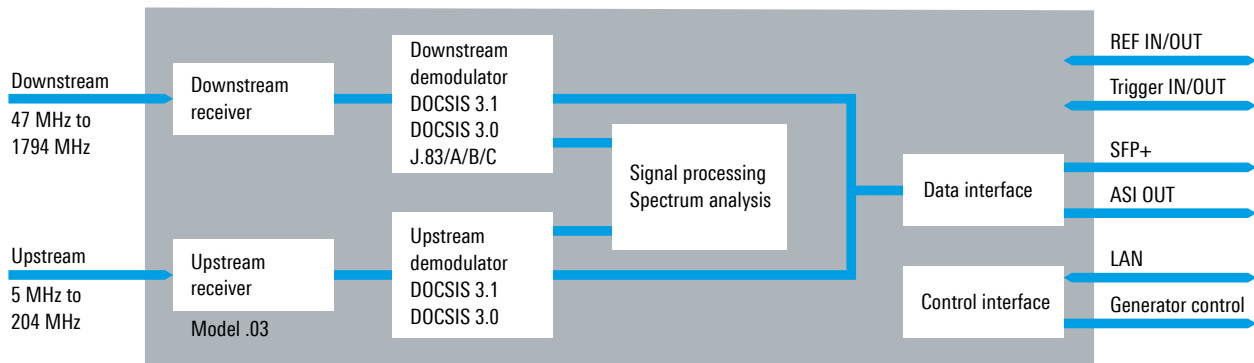

Assessing the quality of an HFC network with the R&S® DSA and a field strength meter

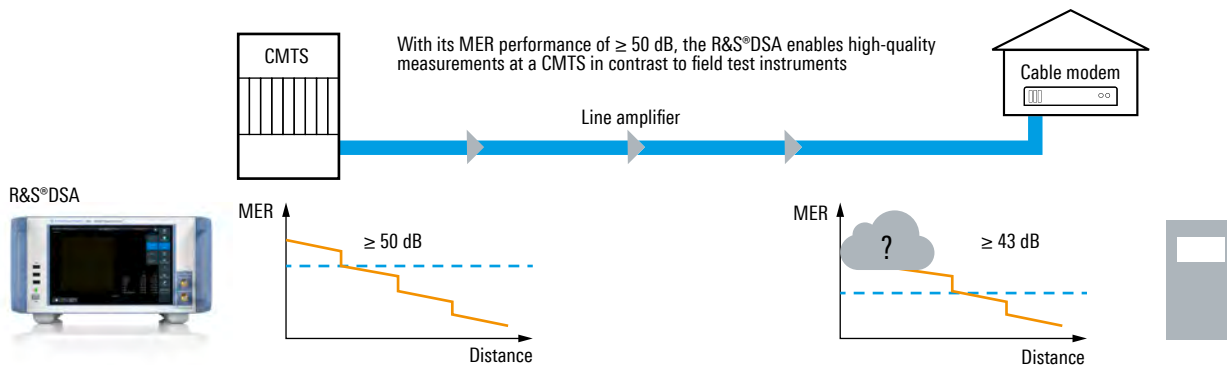

FPGA based demodulation

Demodulation of downstream signals in line with DOCSIS 3.0 (J.83/A/B/C), EuroDOCSIS 3.0 and DOCSIS 3.1 is handled by a powerful field programmable gate array (FPGA). Changes to standards are incorporated by simply upgrading the firmware, making the R&S®DSA a secure investment for the future.

An FPGA based demodulator also eliminates the limitations of measurement performance and precision typically encountered in a modem chipset based field test instrument.

The R&S®DSA meets the claim to be the reference for measurements on the physical DOCSIS layer.

Realtime signal analysis

Realtime stands for fast and gapless signal processing with short refresh cycles when measuring signal characteristics and displaying traces, which significantly simplifies making adjustments and finding sporadic errors.

Maximum performance

To provide the highest possible data rates in the downstream, the DOCSIS 3.1 standard defines a MER value of ≥ 50 dB at the signal output of a CMTS. With its extremely high-quality RF receiver, the R&S®DSA can precisely measure signals at this level of quality, allowing users to assess the limits and margins at every point in the cable TV network.

Integrated spectrum analysis

An integrated spectrum analyzer supplements the versatile signal analysis functionality. Five markers, four phase noise markers, five traces and five user-defined masks are provided for detailed spectrum analysis. Another feature is the ACP measurement, alternatively in the 6 MHz, 7 MHz or 8 MHz grid. The convenient zoom function on the touchscreen makes it easy to navigate within the spectrum.

Downstream DOCSIS 3.1 overview



Downstream DOCSIS 3.1 spectrum analysis

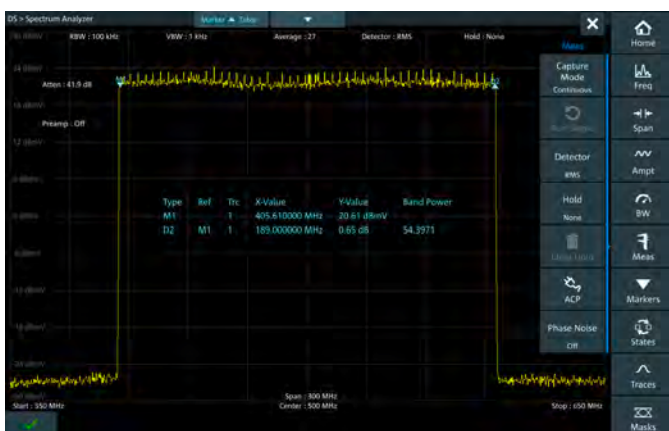

Downstream DOCSIS 3.1 constellation diagram with 4096QAM

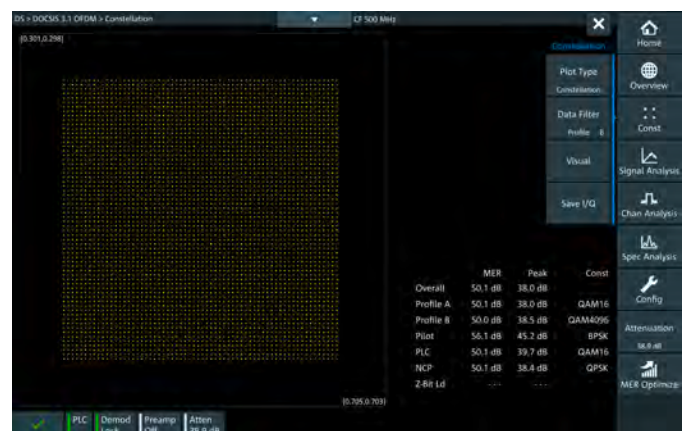

DETAILED ANALYSIS OF UPSTREAM SIGNALS

Up to now, the quality of internet connections has primarily been judged by the maximum download speed, but the upload speed is receiving more and more attention as an additional criterion, driven by cloud services and video uploading to social media platforms.

For higher data throughput in the upstream channel, the DOCSIS 3.1 standard offers an extended frequency range, greater channel bandwidths and modulation formats up to 4096QAM. However, performance may be impaired by cumulative interference originating from the connected cable modems and associated cabling.

Detailed knowledge of the physical conditions on the upstream channel is required in order to optimize data throughput and minimize interference during operation.

Additional RF receiver for upstream signals (model .03)

For analysis of upstream signals, the R&S® DSA model .03 has an additional RF receiver covering the frequency range from 5 MHz to 204 MHz. This receiver enables measurements in cable networks, during production or in the lab, where e.g. simultaneous analysis and monitoring of upstream and downstream signals is required.



Upstream DOCSIS 3.1 overview

FPGA based realtime demodulation

Just as for downstream signals, an FPGA in the R&S®DSA handles demodulation and analysis of upstream signals. Particularly for reliable acquisition and precise analysis of upstream burst signals and the interference that affects them in the upstream channel, high-performance signal processing is essential.

Detailed upstream analysis (R&S®DSA-K1500)

The R&S®DSA-K1500 upstream analysis option enables detailed analysis of A-TDMA (DOCSIS 3.0/EuroDOCSIS) and OFDMA (DOCSIS 3.1) signals. The overview screen, which displays the key signal states and measured values for the specific standard, is the core element of signal analysis. Additional views, including constellation, amplitude, group delay and phase, are available for further analysis of the transmission channel. Especially for long-term measurements, the MER, BER and signal power versus time mea-

surements will be of interest for clearly detecting sporadic events or changes by trend. This enables users to precisely characterize the physical quality of an upstream channel and its components.

For defined transmission of upstream signals, a CMTS communicates the necessary signal parameters in an upstream channel descriptor (UCD). If a CMTS with this information is not available, the signal parameters for analysis of an upstream signal can be manually entered in the R&S®DSA. Particularly in combination with the R&S®SFD DOCSIS® signal generator and R&S®CLGD DOCSIS® cable load generator, this enables users to perform upstream channel analyses even if they do not have a CMTS or a cable modem.

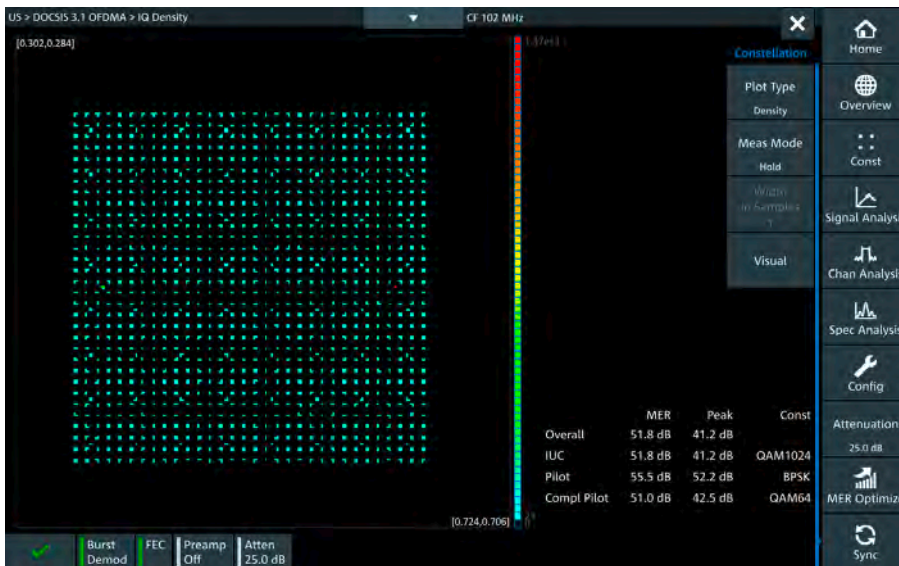

Upstream DOCSIS 3.1 I/Q density with 1024QAM

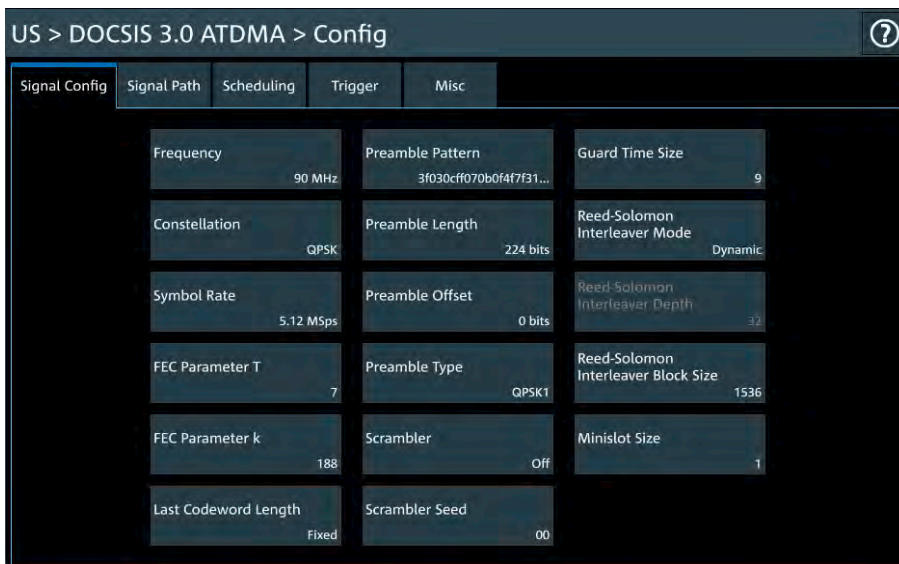

Upstream DOCSIS 3.0 signal configuration

Dynamic upstream signal analysis during live operation

The unique dynamic upstream analysis function requires R&S®DSA model .03 with its two separate RF receivers for the upstream and downstream.

Measurements in the lab or in the field can be performed anywhere on the path between the cable modems and a CMTS or a remote PHY component. All that is needed are suitable test outputs to allow simultaneous access to the upstream and downstream signals.

Synchronizing to pulsed upstream signals is a technical challenge for a conventional signal analyzer, especially when there are a large number of signals in the upstream channel. This is no problem for the R&S®DSA.

Using its powerful signal processing and a complex algorithm, the R&S®DSA optimizes its internal timing based on the distances to the CMTS and the cable modems. Next, the upstream receiver performs a self-configuration based on the upstream channel descriptors (UCD) received via the downstream.

Afterwards, the R&S®DSA starts continuously scanning the selected downstream channel for relevant MAP messages for the designated upstream channel in order to detect the appropriate pulsed upstream signals and creates a list of associated service identifiers (SID). To perform measurements on a specific cable modem, this list can be filtered by media access control address (MAC) or SID.

Dynamic upstream analysis with list of MAC addresses



OFDMA upstream signal with traffic detect threshold set



Upstream signal analysis in HFC CATV networks

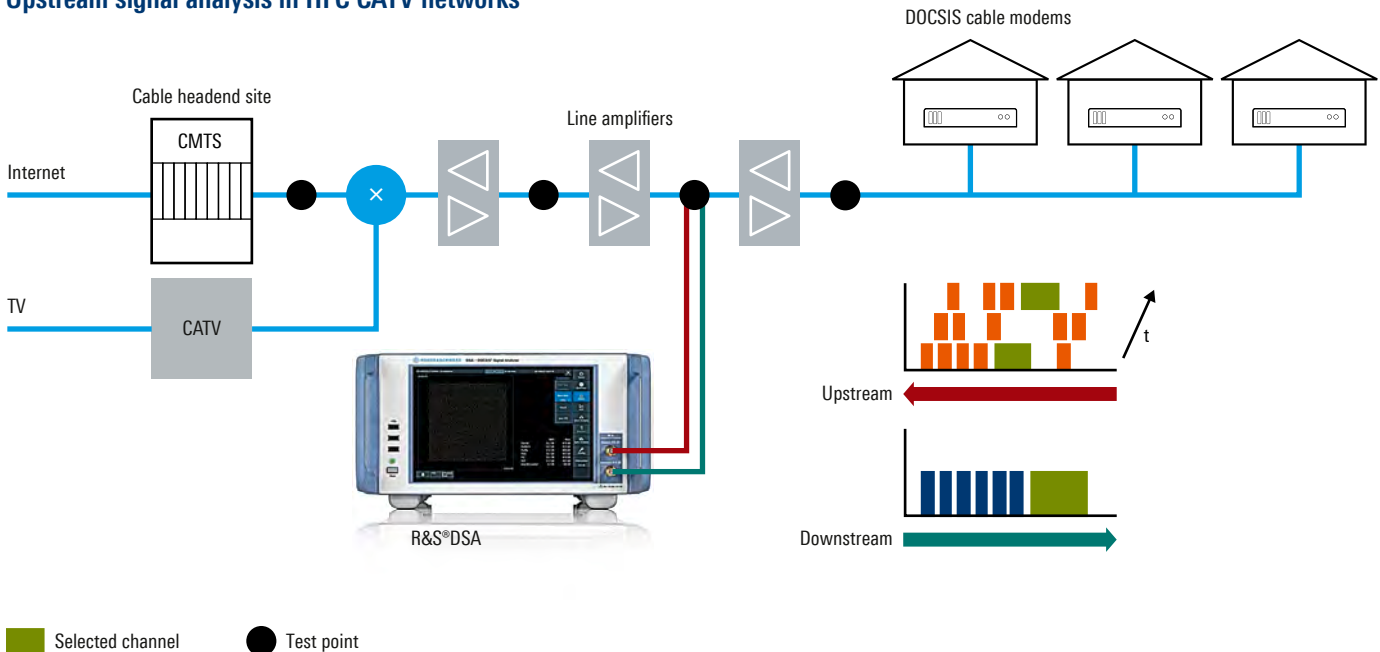

Upstream signal analysis with R&S®SFD

The R&S®DSA DOCSIS® signal analyzer's SFD upstream analysis function offers a convenient way to test and measure network components and network segments using upstream signals.

Here, the R&S®SFD DOCSIS® signal generator serves as a signal source for standard-compliant upstream signals in line with the DOCSIS 3.0 and DOCSIS 3.1 standards.

Using a modulated auxiliary carrier, the signal parameters set on the R&S®SFD are transferred to the R&S®DSA and automatically set. This eliminates the time-consuming and error-prone process of matching the instrument settings to each other.

OFDMA upstream signal with auxiliary carrier at 150 MHz

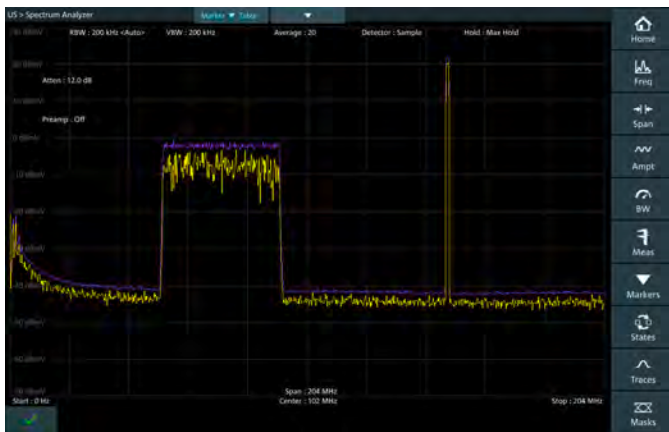

SFD upstream analysis with status display for auxiliary carrier



Testing of network components or network segments in the upstream with the R&S®DSA and R&S®SFD

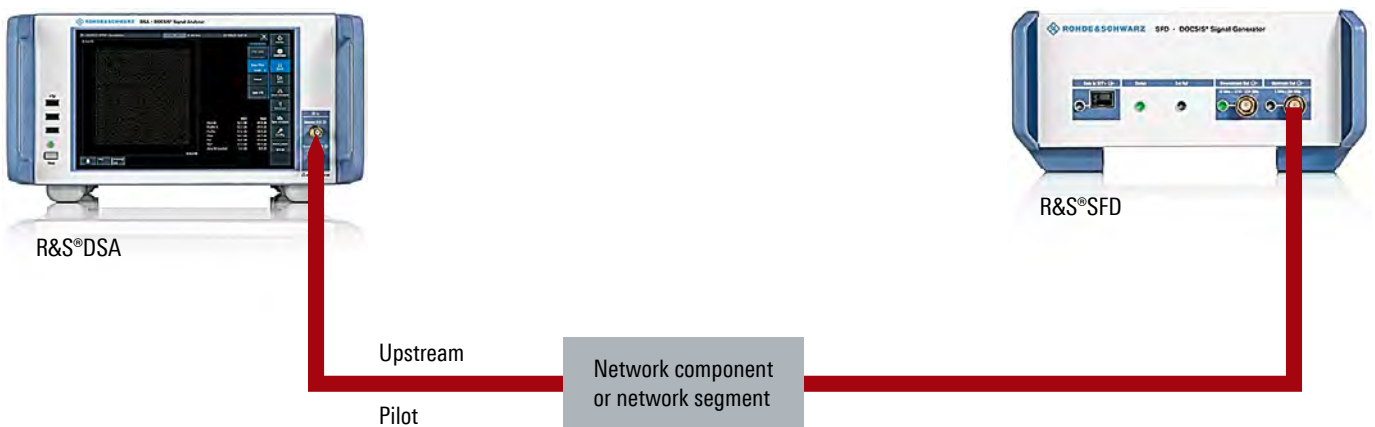

Cable modem ranging test

High-performance operation depends not only on the quality of the network components in the upstream channel, but also on the quality of the upstream signal transmitted by the cable modem. To measure upstream signals transmitted by a cable modem, the R&S®DSA DOCSIS® signal analyzer can be combined with the R&S®SFD DOCSIS® signal generator to form a compact test system.

Here the R&S®SFD takes over some of the tasks of a CMTS in order to trigger ranging by the modem. The R&S®DSA analyzes and displays the quality of the upstream signals transmitted by the modem. This allows fast and easy testing and comparison of cable modems from different manufacturers or production batches.

Cable modem ranging analysis



Cable modem ranging with the R&S®DSA and R&S®SFD

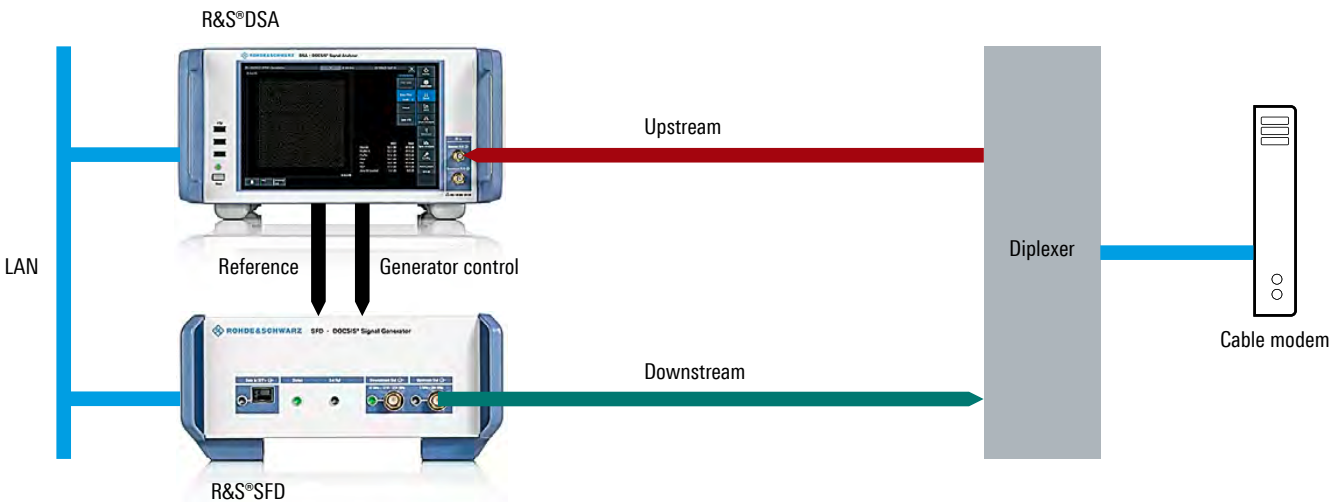

DIGITAL TV SIGNAL ANALYSIS FOR INTERFERENCE-FREE PARALLEL OPERATION WITH DOCSIS

Digital TV will be transmitted over TV cable networks for many years before it is completely replaced by IP TV over DOCSIS. Until then, HFC cable network operators must ensure that DOCSIS and TV channels operate in parallel without negatively affecting one another. Equipped with the R&S®DSA-K1501 option, the R&S®DSA is able to analyze both digital TV and DOCSIS signals.

FPGA based demodulation

The R&S®DSA uses FPGAs to demodulate digital TV signals in line with the J.83/A/B/C and DVB-C standards. For further processing, the demodulated MPEG-2 transport streams are available at the ASI output located at the rear of the R&S®DSA.

Realtime signal analysis

Realtime signal analysis not only offers a speed advantage, it also facilitates measurements such as bit error ratio (BER), modulation error ratio (MER) and signal power versus time and constellation diagram for displaying sporadic errors.

J.83 overview



J.83 constellation diagram with 256QAM

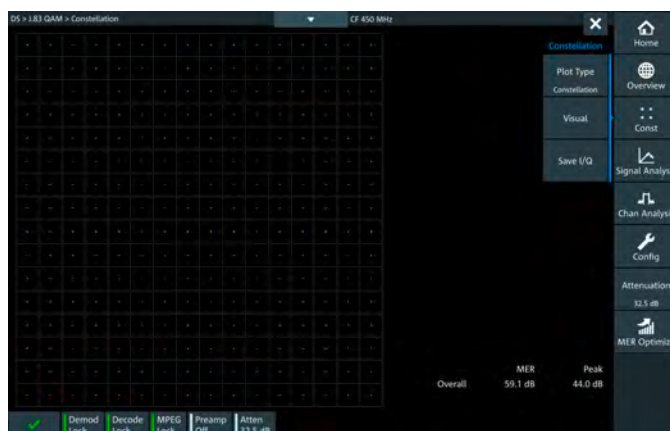

J.83 BER versus time with sporadic errors



AUTOMATIC CHANNEL MEASUREMENTS WITH R&S®TVSCAN 2.0

Today's cable TV systems normally have over one hundred occupied channels. To manually measure these channels separately and record the results would be very time-consuming and expensive. These tasks can be accomplished automatically, effectively, quickly and easily with R&S®TVSCAN 2.0.

Individual channel tables

Automatic measurements are based on the user-defined channel tables, measurements and related limits. All parameters in the channel tables can be predefined so that the R&S®ETL is correctly set for each channel.

Verification in accordance with user-specific limits

Measurements are made in accordance with a selected, user-specific limit table that defines the parameters to be measured and their tolerance limits. The measurement results are stored in an SQLite database on the R&S®DSA, a PC or a network drive. Limit violations are indicated graphically.

2D and 3D visualization of measurement results

Analysis of the measurement results is supported by 2D and 3D graphs of the data. This allows quick analysis of even big data collections so that trends in signal degradation or short-term degradations can be easily identified.

Channel table with individual settings per channel

| Channel Name | D1 | D2 | 3 | 4 | 5 | 6 | 7 | 8 | 9 |
|----------------------------------------|----------------|----------------|----------------|----------------|----------------|----------------|----------------|----------------|----------------|
| Description | DVB-C / 383... | DVB-C / 383... | DVB-C / 383... | DVB-C / 383... | DVB-C / 383... | DVB-C / 383... | DVB-C / 383... | DVB-C / 383... | DVB-C / 383... |
| TV Standard | DVB-C / 383... | DVB-C / 383... | DVB-C / 383... | DVB-C / 383... | DVB-C / 383... | DVB-C / 383... | DVB-C / 383... | DVB-C / 383... | DVB-C / 383... |
| Carrier / Vision Carrier Frequency | 590.00 MHz | 594.00 MHz | 602.00 MHz | 610.00 MHz | 618.00 MHz | 626.00 MHz | 634.00 MHz | 642.00 MHz | 650.00 MHz |
| Frequency Offset | 0.00 Hz | 0.00 Hz | 0.00 Hz | 0.00 Hz | 0.00 Hz | 0.00 Hz | 0.00 Hz | 0.00 Hz | 0.00 Hz |
| Power Level Offset | 0.00 dB | 0.00 dB | 0.00 dB | 0.00 dB | 0.00 dB | 0.00 dB | 0.00 dB | 0.00 dB | 0.00 dB |
| Reference Level Mask | Automatic | Automatic | Automatic | Automatic | Automatic | Automatic | Automatic | Automatic | Automatic |
| Reference Level | 0 dBmV | 0 dBmV | 0 dBmV | 0 dBmV | 0 dBmV | 0 dBmV | 0 dBmV | 0 dBmV | 0 dBmV |
| Pre Selection | On | On | On | On | On | On | On | On | On |
| Pre Amplifier | On | On | On | On | On | On | On | On | On |
| Modulation | Q-AM | Q-AM | Q-AM | Q-AM | Q-AM | Q-AM | Q-AM | Q-AM | Q-AM |
| Subchannel Position (DVB-T2 Inversion) | Automatic | Automatic | Automatic | Automatic | Automatic | Automatic | Automatic | Automatic | Automatic |
| Usage Policy | | | | | | | | | |

3D display of the MER value versus channels and time

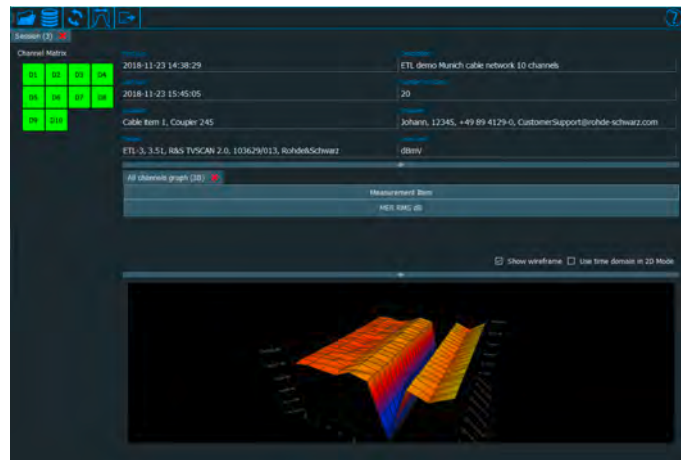

SPECIFICATIONS IN BRIEF

| Specifications in brief | | |
|--------------------------------|-------------------------------------------------------|----------------------------------------------------------|
| RF parameters | | |
| Frequency range | downstream with J.83 QAM | 47 MHz to 1794 MHz |
| | upstream (model .03 only) | 5 MHz to 204 MHz |
| Level | downstream per 24 MHz | up to 67 dBmV (+18 dBm) |
| | upstream (model .03 only) | up to 67 dBmV (+18 dBm) |
| MER (downstream) | 47 MHz to 600 MHz | ≥ 50 dB |
| | 600 MHz to 1000 MHz | ≥ 48 dB |
| | 1000 MHz to 1794 MHz | ≥ 47 dB |
| | with SC-QAM, 100 MHz to 1200 MHz | ≥ 56 dB |
| Spectrum analyzer | | |
| Level accuracy | | ±0.5 dB at +25°C |
| Resolution bandwidth | | 10 Hz to 3 MHz, zero span |
| Downstream demodulation | | |
| DOCSIS 3.0 (SC-QAM) J.83/A/B/C | in line with CM-SP-PHYv3.0, CM-SP-DRFI and ITU-T J.83 | |
| Symbol rate | | 0.4 Msymbol/s to 7.2 Msymbol/s |
| Constellation | | 4QAM to 256QAM (J.83A/C up to 1024QAM) |
| DOCSIS 3.1 (OFDM) | in line with CM-SP-PHYv3.1 | |
| Bandwidth | | up to 192 MHz |
| FFT modes | | 4k, 8k |
| Constellation | | 16QAM to 16384QAM |
| Upstream demodulation | | |
| DOCSIS 3.0 (A-TDMA) | in line with CM-SP-PHYv3.0 | |
| Symbol rate | | 1.28 Msymbol/s to 5.12 Msymbol/s |
| Constellation | | QPSK to 256QAM, DQPSK, DQAM16 |
| DOCSIS 3.1 (OFDMA) | in line with CM-SP-PHYv3.1 | |
| Bandwidth | | up to 96 MHz |
| FFT modes | | 2k, 4k |
| Constellation | | QPSK to 2048QAM |
| General data | | |
| Screen | | 10.1" touchscreen |
| Resolution | | 1280 × 800 pixel |
| Dimensions | W × H × D | 358 mm × 196 mm × 411 mm (14.1 in × 7.7 in × 16.2 in) |
| Weight | | ≤ 7.5 kg (16.5 lb) |

ORDERING INFORMATION

| Designation | Type | Order No. |
|------------------------------------------------------------------------------------------------------------------------------|---------------|--------------|
| Base unit | | |
| DOCSIS® signal analyzer, for DOCSIS and digital cable TV, DOCSIS 3.1 downstream demodulator included | R&S®DSA | 2118.7800.02 |
| DOCSIS® signal analyzer, for DOCSIS and digital cable TV, DOCSIS 3.1 downstream demodulator included, with upstream receiver | R&S®DSA | 2118.7800.03 |
| Accessories supplied | | |
| Power cable, quick start guide | | |
| Software options (firmware) | | |
| Upstream demodulation/analysis | R&S®DSA-K1500 | 2118.7723.02 |
| J.83, D3.0 DS demodulation/analysis | R&S®DSA-K1501 | 2118.7730.02 |
| R&S®TVSCAN 2.0, automated measurement of multiple TV and DOCSIS channels | R&S®DSA-K950 | 2118.8236.02 |
| Extras | | |
| 19" adapter 4E 3/4 T350 | R&S®ZZA-KN11 | 1175.3104.00 |

| Warranty | | |
|-------------------------------------------------------------------|---------|-----------------------------------------|
| Base unit | | 3 years |
| All other items ¹⁾ | | 1 year |
| Options | | |
| Extended warranty, one year | R&S®WE1 | Please contact your local sales office. |
| Extended warranty, two years | R&S®WE2 | |
| Extended warranty with calibration coverage, one year | R&S®CW1 | |
| Extended warranty with calibration coverage, two years | R&S®CW2 | |
| Extended warranty with accredited calibration coverage, one year | R&S®AW1 | |
| Extended warranty with accredited calibration coverage, two years | R&S®AW2 | |
| Extended calibration coverage, two years | R&S®CC2 | |
| Extended calibration coverage, three years | R&S®CC3 | |
| Extended calibration coverage, four years | R&S®CC4 | |
| Extended calibration coverage, five years | R&S®CC5 | |

¹⁾ For options that are installed, the remaining base unit warranty applies if longer than 1 year. Exception: all batteries have a 1 year warranty.

Архангельск (8182)63-90-72
 Астана (7172)727-132
 Астрахань (8512)99-46-04
 Барнаул (3852)73-04-60
 Белгород (4722)40-23-64
 Брянск (4832)59-03-52
 Владивосток (423)249-28-31
 Волгоград (844)278-03-48
 Вологда (8172)26-41-59
 Воронеж (473)204-51-73
 Екатеринбург (343)384-55-89
 Иваново (4932)77-34-06

Ижевск (3412)26-03-58
 Иркутск (395)279-98-46
 Казань (843)206-01-48
 Калининград (4012)72-03-81
 Калуга (4842)92-23-67
 Кемерово (3842)65-04-62
 Киров (8332)68-02-04
 Краснодар (861)203-40-90
 Красноярск (391)204-63-61
 Курск (4712)77-13-04
 Липецк (4742)52-20-81

Магнитогорск (3519)55-03-13
 Москва (495)268-04-70
 Мурманск (8152)59-64-93
 Набережные Челны (8552)20-53-41
 Нижний Новгород (831)429-08-12
 Новокузнецк (3843)20-46-81
 Новосибирск (383)227-86-73
 Омск (3812)21-46-40
 Орел (4862)44-53-42
 Оренбург (3532)37-68-04
 Пенза (8412)22-31-16

Пермь (342)205-81-47
 Ростов-на-Дону (863)308-18-15
 Рязань (4912)46-61-64
 Самара (846)206-03-16
 Санкт-Петербург (812)309-46-40
 Саратов (845)249-38-78
 Севастополь (8692)22-31-93
 Симферополь (3652)67-13-56
 Смоленск (4812)29-41-54
 Сочи (862)225-72-31
 Ставрополь (8652)20-65-13

Сургут (3462)77-98-35
 Тверь (4822)63-31-35
 Томск (3822)98-41-53
 Тула (4872)74-02-29
 Тюмень (3452)66-21-18
 Ульяновск (8422)24-23-59
 Уфа (347)229-48-12
 Хабаровск (4212)92-98-04
 Челябинск (351)202-03-61
 Череповец (8202)49-02-64
 Ярославль (4852)69-52-93

Киргизия (996)312-96-26-47

Россия (495)268-04-70

Казахстан (772)734-952-31

<https://rohdeschwarz.nt-rt.ru> || rwz@nt-rt.ru