

Компактная тестовая платформа CEMS100



Архангельск (8182)63-90-72
Астана (7172)727-132
Астрахань (8512)99-46-04
Барнаул (3852)73-04-60
Белгород (4722)40-23-64
Брянск (4832)59-03-52
Владивосток (423)249-28-31
Волгоград (844)278-03-48
Вологда (8172)26-41-59
Воронеж (473)204-51-73
Екатеринбург (343)384-55-89
Иваново (4932)77-34-06

Ижевск (3412)26-03-58
Иркутск (395)279-98-46
Казань (843)206-01-48
Калининград (4012)72-03-81
Калуга (4842)92-23-67
Кемерово (3842)65-04-62
Киров (8332)68-02-04
Краснодар (861)203-40-90
Красноярск (391)204-63-61
Курск (4712)77-13-04
Липецк (4742)52-20-81

Киргизия (996)312-96-26-47

Магнитогорск (3519)55-03-13
Москва (495)268-04-70
Мурманск (8152)59-64-93
Набережные Челны (8552)20-53-41
Нижний Новгород (831)429-08-12
Новокузнецк (3843)20-46-81
Новосибирск (383)227-86-73
Омск (3812)21-46-40
Орел (4862)44-53-42
Оренбург (3532)37-68-04
Пенза (8412)22-31-16

Россия (495)268-04-70

Пермь (342)205-81-47
Ростов-на-Дону (863)308-18-15
Рязань (4912)46-61-64
Самара (846)206-03-16
Санкт-Петербург (812)309-46-40
Саратов (845)249-38-78
Севастополь (8692)22-31-93
Симферополь (3652)67-13-56
Смоленск (4812)29-41-54
Сочи (862)225-72-31
Ставрополь (8652)20-65-13

Казахстан (772)734-952-31

Сургут (3462)77-98-35
Тверь (4822)63-31-35
Томск (3822)98-41-53
Тула (4872)74-02-29
Тюмень (3452)66-21-18
Ульяновск (8422)24-23-59
Уфа (347)229-48-12
Хабаровск (4212)92-98-04
Челябинск (351)202-03-61
Череповец (8202)49-02-64
Ярославль (4852)69-52-93

<https://rohdeschwarz.nt-rt.ru> || rwz@nt-rt.ru

R&S®CEMS100 Compact EMS/EMI Test Platform At a glance



Setting up an EMS/EMI test system is a very complex process requiring significant investment. The steps involved include custom planning, design, installation and configuration of various components and standalone instruments as well as the RF-shielded anechoic chamber. is now offering the standardized R&S®CEMS100 test platform that is the company's first flexible, reliable and cost-effective off-the-shelf solution for radiated EMS measurements in line with IEC/EN 61000-4-3.

The advanced R&S®CEMS100 is a compact EMS/EMI test platform covering all common frequency ranges and field strengths needed for precompliance tests and certification. It meets three important requirements for an EMS test system:

- ▮ The test system offers assured overall performance when combined with qualified test chambers; the attainable field strength was determined based on extensive measurements performed together with chamber manufacturer Albatross Projects GmbH; as a result, compliance with the relevant test standards is ensured
- ▮ As a standardized and preconfigured all-in-one solution, the test system allows efficient field generation with outstanding field uniformity; users can install and start up the test system on their own; it represents a highly efficient and cost-effective solution for certification and development
- ▮ The test system's modular design allows worldwide support and calibration services and can be expanded to handle new technologies

The core of the platform consists of various system components such as signal generators, switching units, broadband amplifiers and EMC software. These components can be easily exchanged, expanded or upgraded without modifying the base system. Using a test receiver with the appropriate software option, the system can be expanded to perform automated EMI measurements without changing antennas.

Key facts

- ▮ Certifiable base system for commercial standards
- ▮ EMS measurements from 80 MHz to 3 GHz, 10 V/m
- ▮ EMS and EMI measurements without changing antennas
- ▮ Scalable and expandable for further EMC applications
- ▮ Various proven EUT monitoring capabilities
- ▮ Immediate deployment with preconfigured hardware and software

R&S®CEMS100

Compact EMS/EMI

Test Platform

Benefits and key features

All-in-one solution from the market leader in EMC T&M equipment

- ▮ Ideally matched components for top efficiency
- ▮ Defined system characteristics including assured field strength
- ▮ Combinable with many different EMC test chambers
- ▮ Complete test system ready to put into operation

▷ [page 4](#)

Efficient

- ▮ Scalable system, optimized for certification and development
- ▮ Easy expansion for EMI with test receiver and software option
- ▮ EMS and EMI measurements without changing antennas
- ▮ Easy integration into existing EMC test environments
- ▮ Worldwide support and service with 24 h telephone support

▷ [page 7](#)

Future-ready

- ▮ Flexibility to handle ongoing technological advances with standard measuring instruments
- ▮ Options for all common EMC test applications
- ▮ Prepared for 6 GHz, conducted measurements and performance upgrades

▷ [page 8](#)

All-in-one solution from the market leader in EMC T & M equipment

Ideally matched components for top efficiency

Efficient generation of fields is crucial in an EMS test system. The best performance is achieved through high amplifier power in combination with minimal cable losses, an efficient antenna to ideally illuminate the homogeneous area and an optimum absorber layout. In the R&S®CEMS100, a high-performance EMS/EMI hybrid antenna is used to cover the complete frequency range.

Moreover, the amplifier power is matched to the antenna gain. Thanks to the compact system design and full remote control via LAN, the system can be operated in small test chambers directly next to the chamber's connector panel. In conjunction with low-loss RF cables, top RF performance is achieved at the antenna.

Components of the R&S®CEMS100

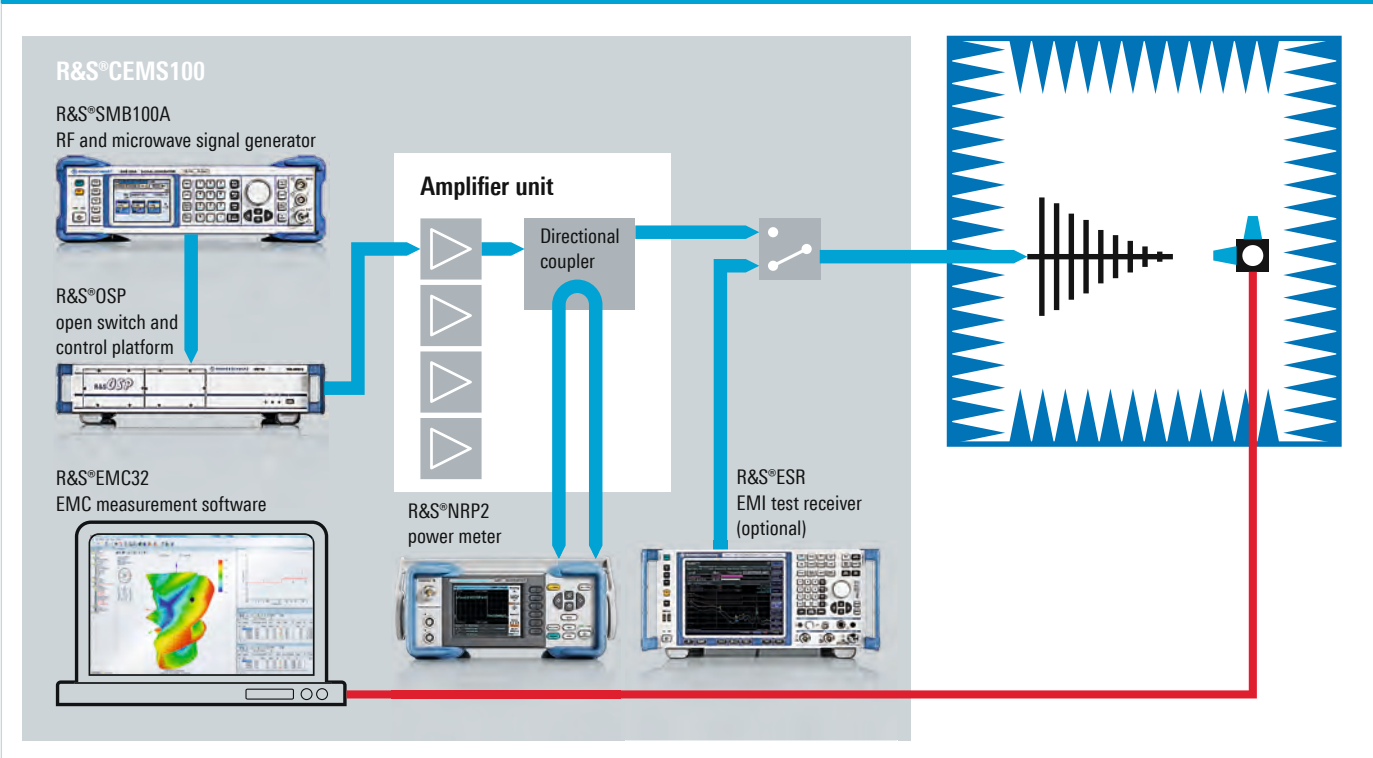

The R&S®CEMS100 includes all the components required in an advanced EMS test system:

- ▮ Signal generator with amplitude modulation (AM)
- ▮ Switching unit for all RF paths
- ▮ Broadband amplifier with diverse control options
- ▮ Power meter with two power sensors
- ▮ High-performance hybrid antenna for EMS and EMI measurements
- ▮ Interlock monitoring for protection of personnel during EMS testing
- ▮ Full-compliance test software for cost-effective, fully automated EMS measurements based on the market-leading R&S®EMC32 EMC measurement software
- ▮ Options
 - R&S®ESR EMI test receiver or R&S®ESRP EMI test receiver and R&S®EMC32 EMI software options
 - EMC test chamber: qualified for use in various types of chambers
 - Field probe

Defined system characteristics including assured field strength

A major investment is required to build an EMC test setup that includes a test chamber and test system. Accordingly, it is prudent to plan ahead and avoid tedious or costly optimizations that might be required subsequently. Such problems are prevented from the start when the R&S®CEMS100 is combined with different EMC anechoic chamber types from Albatross Projects GmbH since the R&S®CEMS1xx has already been qualified for use in these chambers. A field strength of 10 V/m + 80% AM is reliably achieved and assured across the entire frequency range. The cable lengths are matched to the chamber. A list of chamber types is available upon request.

Configuration of disturbance signal generation with an R&S®CEMS100 for EMS testing.

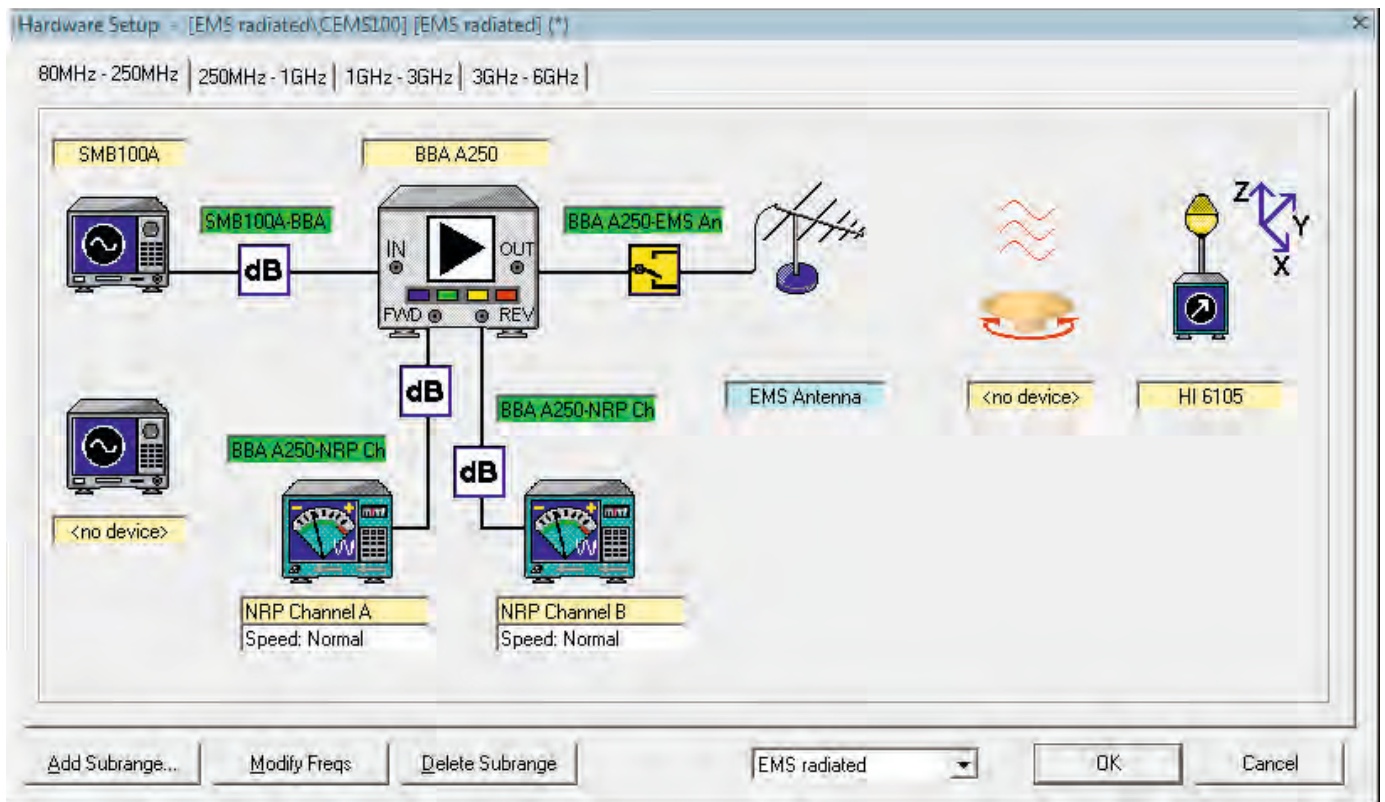

Combinable with many different EMC test chambers

The test chamber has a major impact on the field strength. This is due to effects such as chamber resonance, absorber layout and distance from the absorbers to the antenna or homogeneous area. The R&S®CEMS100 is designed for a field strength of 18 V/m CW (or 10 V/m with 80% AM) based on experience gained with a number of test systems.

When using small chambers, deviations can arise in some subfrequency ranges so that the intended field strength is not attained under certain circumstances ¹⁾.

¹⁾ In some cases, modifying the floor absorber layout will improve the situation.

Complete test system ready to put into operation

The R&S®CEMS100 all-in-one solution provides top system performance and comes with the complete documentation. The test system is fully tested and – if possible without a test chamber – supplied in a calibrated and preconfigured state including all transducer and directional coupler values.

Only the field strength over the homogeneous area has to wait to be calibrated in the chamber.

Power required in a 3 m semi-anechoic chamber from Albatross Projects GmbH for vertical and horizontal polarization with 4x4 floor absorber layout

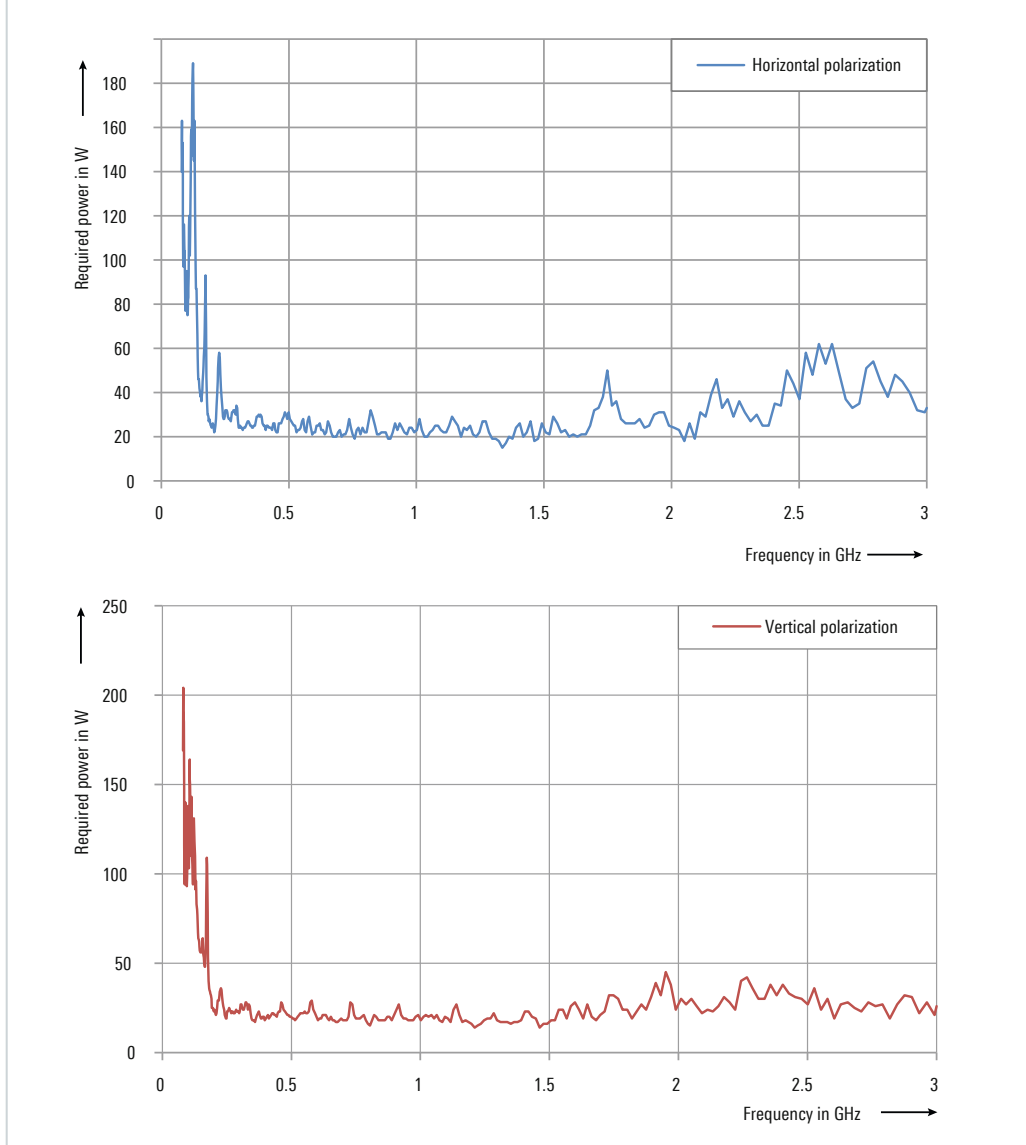

Efficient

Scalable system, optimized for certification and development

Depending on the particular measurement task (100% standard-compliant testing or cost-effective solution for precompliance tests), frequency ranges from 80 MHz to 1 GHz (or 3 GHz) are available along with various amplifier power levels. For example, the R&S®CEMS130 (frequency range up to 3 GHz) can perform acceptance tests and precompliance tests in line with IEC/EN 61000-4-3 and a related product standard such as EN 55024 for information technology equipment (ITE).

Overview of system variants		
Type	Frequency	Performance
R&S®CEMS110	80 MHz to 1 GHz	100% standard-compliant
R&S®CEMS111	80 MHz to 1 GHz	for precompliance tests ²⁾
R&S®CEMS130	80 MHz to 3 GHz	100% standard-compliant
R&S®CEMS131	80 MHz to 3 GHz	for precompliance tests ²⁾

²⁾ In individual small frequency subranges, the field strength is possibly not attained.

Easy expansion for EMI with test receiver and software option

Since EMI and EMS measurements are performed in most test chambers, the system is ready for both types of measurements. Along with the R&S®ESR EMI test receiver for full-compliance measurements or the R&S®ESRP EMI test receiver for precompliance measurements, the EMI option also includes the appropriate R&S®EMC32 software options to allow automated EMI tests with a turntable and mast controller. It also allows automatic switching between emission and EMS measurements without reconnecting the test receiver. Using the optional R&S®EMC32-K11 test sequencer, EMI and EMS measurements can be automatically performed in sequence.

EMS and EMI measurements without changing antennas

Changing antennas in the test chamber is a time-consuming process since the antennas can be unwieldy and it is usually necessary to reposition the absorbers. One benefit here is that the antenna used in the R&S®CEMS100 covers the complete frequency range for common commercial radiated EMC measurements from 30 MHz to 6 GHz for EMI and from 80 MHz to 3 GHz for EMS in line with CISPR and EN standards.

During testing in a fully anechoic room (FAR) with a floor absorber between antenna and EUT without a height scan (measurement distance of 3 m from antenna phase center to EUT), it is possible to switch directly between emission and EMS measurements without reconfiguration. The EMI option is necessary for these tests.

Easy integration into existing EMC test environments

The R&S®CEMS100 control software is the tried and tested R&S®EMC32, which is used on a daily basis in many test laboratories worldwide. User experience is tapped continuously to aid in further development of the software. Users and test houses that already rely on the R&S®EMC32 software have confirmed that it is very easy to integrate the R&S®CEMS100 into existing test environments.

Worldwide support and service with 24 h telephone support

In contrast to standalone custom solutions, a standardized system makes expert knowledge widely and readily available. To ensure that work proceeds smoothly in test laboratories, test engineers can take advantage of customer support and 24 h telephone support at regional system centers as well as locally.

Future-ready

Flexibility to handle ongoing technological advances with standard measuring instruments

The core of the R&S®CEMS100 consists of various system components such as signal generators, switching units, broadband amplifiers and EMC software. These components can be easily ex-changed, expanded or upgraded without modifying the base system. The customary fast calibration service from is also available for the test platform.

Assuming the R&S®EMC32 software provides appropriate support, other measuring instruments with comparable functionality can be deployed in the system, e.g. as a substitute during calibration. This ensures high system availability for the user.

Extensive functionality for EUT monitoring via diverse interfaces

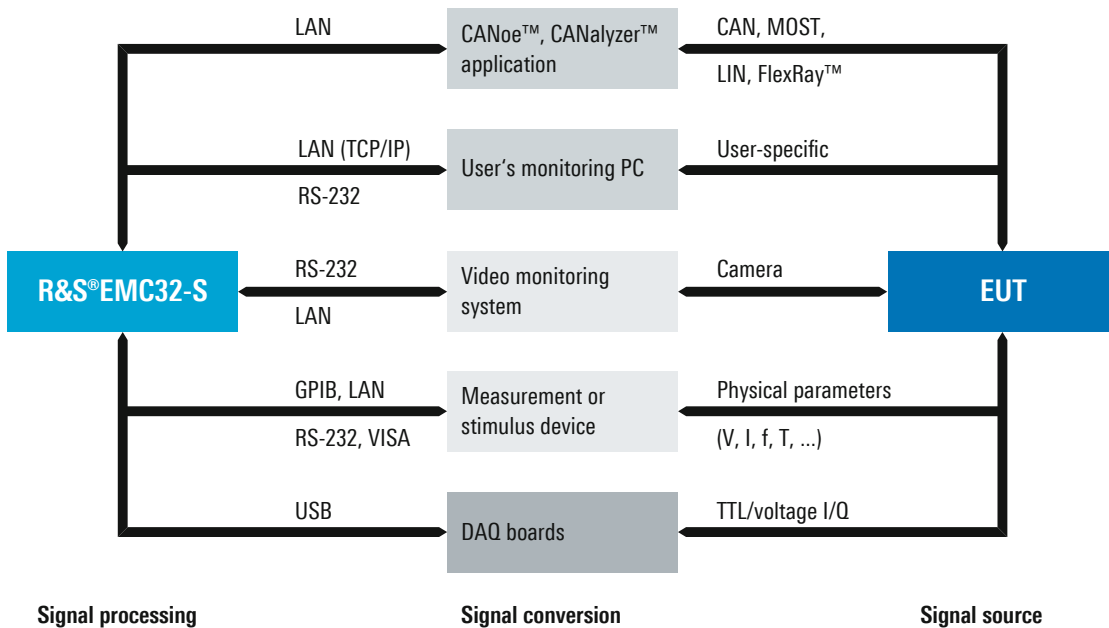

Options for all common EMC test applications

In its basic configuration, the R&S®EMC32 EMC measurement software already offers all the functionality needed to operate the R&S®CEMS100. This also includes powerful integrated functions for EUT monitoring such as control and query of individual measuring instruments and I/O interfaces, communications with EUT and video monitoring software or with in-vehicle electronics systems via CANoe™ or CANalyzer™. All this allows users to easily handle interfacing of the EUT controller and tests.

Moreover, the R&S®EMC32 software offers all relevant expansion options for present and future measurement tasks, including options for automotive and MIL standards, wireless measurements and support for reverberation chambers.

Prepared for 6 GHz, conducted measurements and performance upgrades

The R&S®CEMS100 is prepared for the frequency range from 80 MHz to 6 GHz. This applies to all its key components including the signal generator, power measurement equipment and antenna. By adding an amplifier for 3 GHz to 6 GHz, the frequency range of the system platform can be extended very easily.

An extension downward is also possible for conducted measurements. Since the frequency range including the amplifier starts at 9 kHz, only the appropriate transducers such as coupling/decoupling networks (CDN), EM clamps or bulk current injection (BCI) clamps and a 6 dB attenuator are needed. Using suitable transducers, the amplifier power is adequate for much more than 10 V + 80% AM.

Due to its modular design, power upgrades for the amplifier are easy to implement since service only has to install additional modules. As a result, standards that require higher test levels can be covered as well.

Overview of available R&S®EMC32 options

Opt.	Opt.	Opt.	Opt.	Opt.	Opt.	Opt.	Opt.	Opt.	Opt.	Opt.	Opt.	Opt.	Opt.	Opt.	Opt.	Opt.	Opt.
R&S®EMC32-K56	R&S®EMC32-K51	R&S®EMC32-K22	R&S®EMC32-K23	R&S®EMC32-K24	R&S®EMC32-K33	R&S®EMC32-K10	R&S®EMC32-K2	R&S®EMC32-K251	R&S®EMC32-K26	R&S®EMC32-K1	R&S®EMC32-K3	R&S®EMC32-K4	R&S®EMC32-K6	R&S®EMC32-K8	R&S®EMC32-K21	R&S®EMC32-K7	R&S®EMC32-K11
EMI tests in line with MIL-STD-461	EMI band evaluations	azimuth charts	3D result evaluation	interactive autotest extension	RVC EMI test	EMI autotest	radiocommunications tests	TD-SCDMA support	LTE support	automotive and military EMS tests	RVC EMS test	EMS autotest	MIL-STD CS103, 104, 105	database interface	application interface	generic device drivers	test sequencer
-K56	-K51	-K22	-K23	-K24	-K33	-K10	-K2	-K251	-K26	-K1	-K3	-K4	-K6	-K8	-K21	-K7	-K11
R&S®EMC32-EB Basic emission measurements							R&S®EMC32-S Basic immunity measurements					R&S®EMC32 General options					

Specifications in brief

Specifications in brief		
Frequency range of R&S®CEMS110/111	EMS	80 MHz to 1 GHz
Frequency range of R&S®CEMS130/131	EMS	80 MHz to 3 GHz
Frequency range	EMI (optional with appropriate test receiver)	30 MHz to 6 GHz
Field strength (100% standard-compliant) for R&S®CEMS110/130	80% AM 1 kHz; meets uniformity in line with IEC/ EN 61000-4-3 for an area of 1.5 m × 1.5 m in a qualified 3 m semi-anechoic chamber (SAC); distance from antenna phase center to EUT: 3 m	10 V/m
Field strength (for precompliance tests) for R&S®CEMS111/131	80% AM 1 kHz; meets uniformity in line with IEC/ EN 61000-4-3 for an area of 1.5 m × 1.5 m in a typical 3 m semi-anechoic chamber (SAC); distance from antenna phase center to EUT: 3 m	10 V/m (typ.) ¹⁾
Modulation		AM, CW pulse (optional)
Software features		<ul style="list-style-type: none"> ■ automatic determination of immunity thresholds ■ measurement of radiated and conducted susceptibility ■ use in product certification and precompliance tests ■ measurements in line with commercial, military and automotive standards ■ flexible adaptation to requirements of various EMC applications ■ automatic control of system components ■ integrated calibration concept ■ various capabilities for EUT monitoring and stimulation ■ interface to external EUT monitoring software ■ flexible report generation (HTML, RTF, PDF) ■ EUT-specific or application-specific data management ■ operation of overall system like a single instrument
Power supply		
Input voltage range		100 V to 240 V, 50 Hz to 60 Hz, autoranging
Power consumption	230 V, single-phase, CEE connector, 16 A, 6 h	max. 1500 VA ²⁾
Antenna data		
Frequency range		30 MHz to 6 GHz
VSWR	starting at 200 MHz	2 (typ.)
Antenna gain	starting at 200 MHz	8.5 dBi (typ.)
Connector		N female
Impedance		50 Ω
General data		
Environmental conditions	operating temperature range	+5°C to +40°C
	storage temperature range	-20°C to +70°C
	relative humidity	90% at +40°C
Electromagnetic compatibility	electromagnetic interference < 1 GHz	EMI emission limits for devices in class A of 40 dB in line with EN 55011 group 1 or FCC 047 CFR part 18 are exceeded; the system may only be used in shielded rooms
	electromagnetic interference ≥ 1 GHz	EMI emission limits for devices in class A of 40 dB in line with EN 55011 group 2 or FCC 047 CFR part 18 are exceeded; the system may only be used in shielded rooms
Dimensions (W × H × D)		600 mm × 1600 mm × 800 mm (23.6 in × 63 in × 31.5 in)
Weight		max. 185 kg (408 lb)

¹⁾ In individual small frequency subranges, the field strength is possibly not attained.

²⁾ Depends on system configuration.

Ordering information

Designation	Type	Order No.
Compact EMS/EMI Test Platform, 80 MHz to 1 GHz (100% standard-compliant)	R&S®CEMS110	1521.5002.02
Compact EMS/EMI Test Platform, 80 MHz to 1 GHz (for precompliance tests) ¹⁾	R&S®CEMS111	1520.7799.02
Compact EMS/EMI Test Platform, 80 MHz to 3 GHz (100% standard-compliant)	R&S®CEMS130	1521.5019.02
Compact EMS/EMI Test Platform, 80 MHz to 3 GHz (for precompliance tests) ¹⁾	R&S®CEMS131	1521.5025.02
Options		
Accessories for Conducted EMS (attenuators, cables, CDN 801-M2/M3 with calibration unit)	R&S®CEMS-ZCS	1522.7838.02
RF Cable for Conducted EMS, system output for RF feedthrough for R&S®CEMS-ZCS	R&S®CEMS-CCON	1522.7796.02
Field Probe Mast and Fiber-Optic Cables (duplex) FC (male)/ST (male), consisting of cables (length: 5 m and 15 m) and fiber-optic feedthrough	R&S®CEMS-FP01	1520.7899.02
Field Probe Mast and Fiber-Optic Cables (duplex) HFBR-45xx (male)/HFBR-45xx (male), consisting of cables (length: 5 m and 15 m) and fiber-optic feedthrough	R&S®CEMS-FP02	1520.7901.02
Equipment supplied		
Rack, set of cables, measuring instruments, amplifiers, antenna, control computer with installed software, documentation. Anechoic chamber, antenna mast, turntable, controller for antenna mast/turntable, field probe not included.		

¹⁾ In individual small frequency subranges, the field strength is possibly not attained.

Service options		
Extended Warranty, one year	R&S®WE1	Please contact your local sales office.
Extended Warranty, two years	R&S®WE2	
Extended Warranty, three years	R&S®WE3	
Extended Warranty, four years	R&S®WE4	
Extended Warranty with Calibration Coverage, one year	R&S®CW1	
Extended Warranty with Calibration Coverage, two years	R&S®CW2	
Extended Warranty with Calibration Coverage, three years	R&S®CW3	
Extended Warranty with Calibration Coverage, four years	R&S®CW4	

Архангельск (8182)63-90-72
Астана (7172)727-132
Астрахань (8512)99-46-04
Барнаул (3852)73-04-60
Белгород (4722)40-23-64
Брянск (4832)59-03-52
Владивосток (423)249-28-31
Волгоград (844)278-03-48
Вологда (8172)26-41-59
Воронеж (473)204-51-73
Екатеринбург (343)384-55-89
Иваново (4932)77-34-06

Ижевск (3412)26-03-58
Иркутск (395)279-98-46
Казань (843)206-01-48
Калининград (4012)72-03-81
Калуга (4842)92-23-67
Кемерово (3842)65-04-62
Киров (8332)68-02-04
Краснодар (861)203-40-90
Красноярск (391)204-63-61
Курск (4712)77-13-04
Липецк (4742)52-20-81

Киргизия (996)312-96-26-47

Магнитогорск (3519)55-03-13
Москва (495)268-04-70
Мурманск (8152)59-64-93
Набережные Челны (8552)20-53-41
Нижний Новгород (831)429-08-12
Новокузнецк (3843)20-46-81
Новосибирск (383)227-86-73
Омск (3812)21-46-40
Орел (4862)44-53-42
Оренбург (3532)37-68-04
Пенза (8412)22-31-16

Россия (495)268-04-70

Пермь (342)205-81-47
Ростов-на-Дону (863)308-18-15
Рязань (4912)46-61-64
Самара (846)206-03-16
Санкт-Петербург (812)309-46-40
Саратов (845)249-38-78
Севастополь (8692)22-31-93
Симферополь (3652)67-13-56
Смоленск (4812)29-41-54
Сочи (862)225-72-31
Ставрополь (8652)20-65-13

Казахстан (772)734-952-31

Сургут (3462)77-98-35
Тверь (4822)63-31-35
Томск (3822)98-41-53
Тула (4872)74-02-29
Тюмень (3452)66-21-18
Ульяновск (8422)24-23-59
Уфа (347)229-48-12
Хабаровск (4212)92-98-04
Челябинск (351)202-03-61
Череповец (8202)49-02-64
Ярославль (4852)69-52-93

<https://rohdeschwarz.nt-rt.ru> || rwz@nt-rt.ru